



US006481928B1

(12) **United States Patent**  
**Doolaege**

(10) **Patent No.:** **US 6,481,928 B1**  
(45) **Date of Patent:** **Nov. 19, 2002**

(54) **FLEXIBLE HYDRAULIC STRUCTURE AND SYSTEM FOR REPLACING A DAMAGED PORTION THEREOF**

(76) Inventor: **David Doolaege**, P.O. Box 206, Carlotta, CA (US) 95528

(\*) Notice: Subject to any disclaimer, the term of this patent is extended or adjusted under 35 U.S.C. 154(b) by 0 days.

(21) Appl. No.: **09/650,265**  
(22) Filed: **Jul. 26, 2000**

**Related U.S. Application Data**

(60) Continuation-in-part of application No. 09/385,820, filed on Aug. 30, 1999, which is a division of application No. 08/939,471, filed on Sep. 22, 1997, now abandoned.

(51) **Int. Cl.**<sup>7</sup> ..... **E02B 7/20**; E02B 7/50; E01F 7/00

(52) **U.S. Cl.** ..... **405/115**; 405/16; 405/21; 405/52; 405/91; 156/294; 138/98

(58) **Field of Search** ..... 405/15, 16, 21, 405/52, 91, 115, 146, 150.1, 154.1, 183.5, 184.1, 184.2; 114/266, 267; 138/97, 98; 156/294, 287

(56) **References Cited**

**U.S. PATENT DOCUMENTS**

2,609,666	A	9/1952	Mesnager	
3,246,474	A	4/1966	Mesnager	
3,355,851	A	12/1967	Imbertson et al.	
3,373,568	A	3/1968	Hornbostel, Jr.	
3,834,167	A	9/1974	Tabor	
3,957,098	A	5/1976	Hepworth et al.	
4,064,211	A	* 12/1977	Wood	156/287 X
4,279,540	A	7/1981	Suga et al.	
4,299,514	A	11/1981	Muramatsu et al.	
4,314,774	A	2/1982	Tsuji et al.	
4,352,591	A	10/1982	Thompson	
4,501,788	A	2/1985	Clem	
4,555,201	A	11/1985	Paoluccio	
4,602,974	A	* 7/1986	Wood et al.	156/294 X
4,690,585	A	9/1987	Holmberg	

4,729,691	A	3/1988	Sample	
4,770,562	A	* 9/1988	Muller et al.	405/154.1
4,784,520	A	11/1988	Stevens	
4,799,821	A	1/1989	Brodersen	
4,966,491	A	10/1990	Sample	
5,034,180	A	* 7/1991	Steketee, Jr.	156/294 X
5,040,919	A	8/1991	Hendrix	
5,059,065	A	10/1991	Doolaege	
5,125,767	A	6/1992	Doolaege	
5,265,648	A	* 11/1993	Lyon	138/98
5,280,811	A	* 1/1994	Catallo et al.	139/98
5,487,411	A	* 1/1996	Goncalves	138/98
5,501,248	A	* 3/1996	Kiest, Jr.	138/98
5,645,373	A	7/1997	Jenkins	
5,725,328	A	* 3/1998	Schmager	405/154.1 X
5,765,597	A	* 6/1998	Kiest, Jr. et al.	156/294 X
5,785,455	A	7/1998	Eaker	
5,846,025	A	* 12/1998	Kamiyama et al.	405/154.1
5,857,806	A	* 1/1999	Melin	405/115
5,865,564	A	2/1999	Miller et al.	
5,975,878	A	* 11/1999	Wood et al.	425/503
6,024,910	A	* 2/2000	Kamiyama et al.	156/294 X
6,136,135	A	* 10/2000	Kamiyama et al.	156/294

**FOREIGN PATENT DOCUMENTS**

GB	2082708	* 3/1982	138/97
JP	63286323	* 11/1988	138/97

\* cited by examiner

*Primary Examiner*—Heather Shackelford  
*Assistant Examiner*—Jong-Suk Lee  
(74) *Attorney, Agent, or Firm*—M. Reid Russell

(57) **ABSTRACT**

A water structure formed from at least one flexible tube or sleeve, that functions as a water containment vessel when at least partially filled with water and closed at its ends, and includes a rope positioned therein. The rope is for connection, on one end, to a second flexible tube or sleeve and is for use in pulling the second flexible tube or sleeve through the first tube or sleeve. The second tube is then to receive a volume of water therein, that expands the second tube against the first tube inner surface to function as a water structure.

**4 Claims, 9 Drawing Sheets**

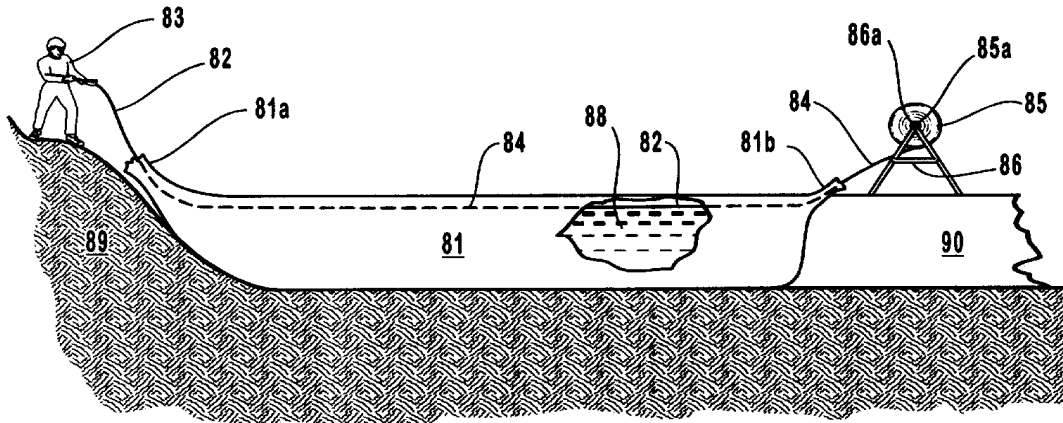

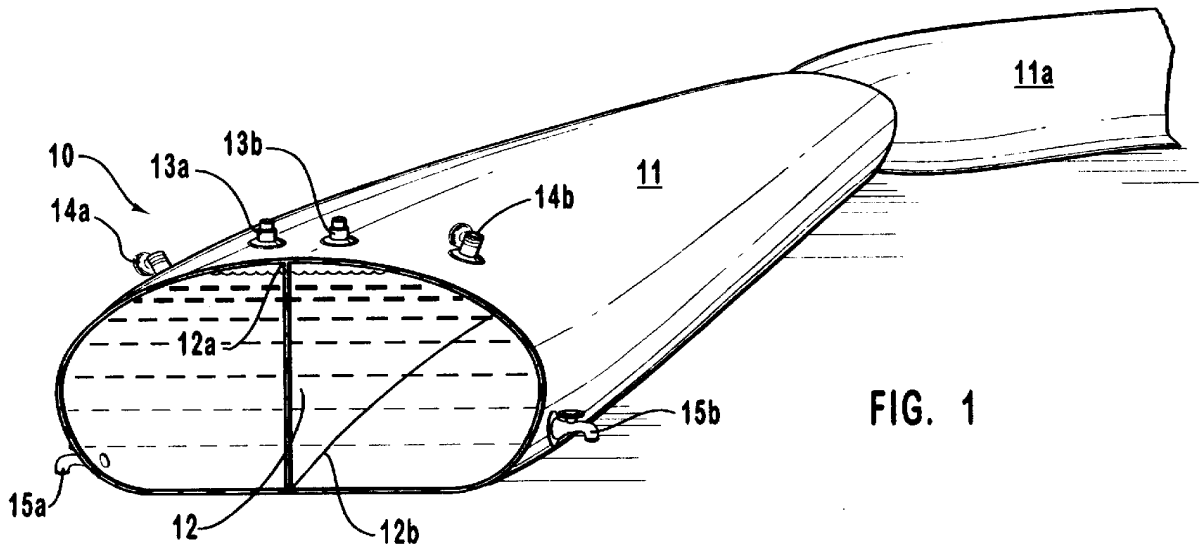

FIG. 1

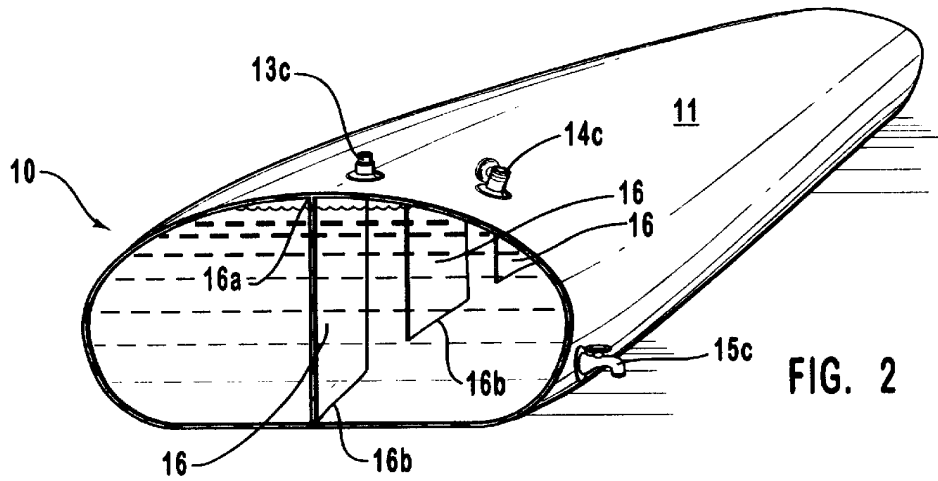

FIG. 2

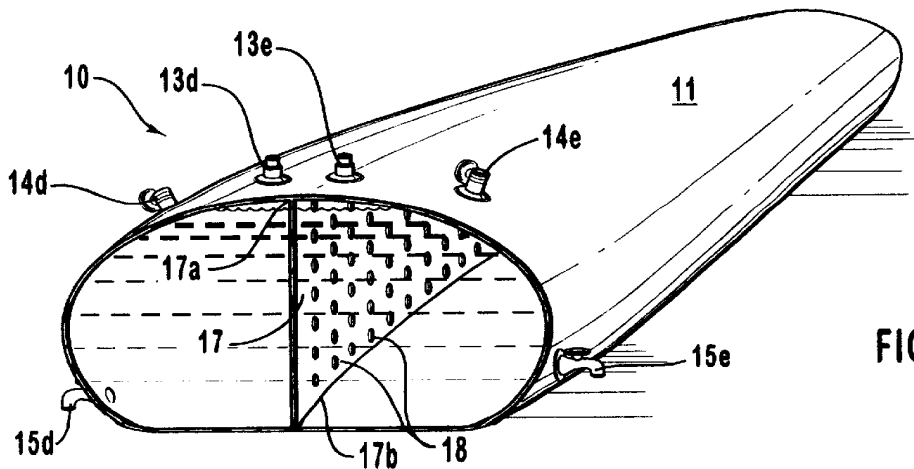

FIG. 3

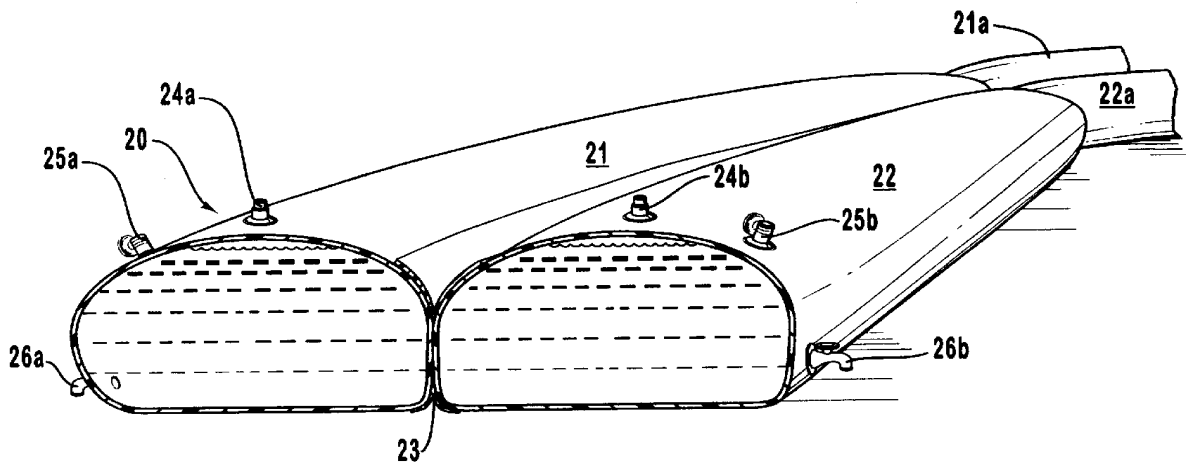

FIG. 4

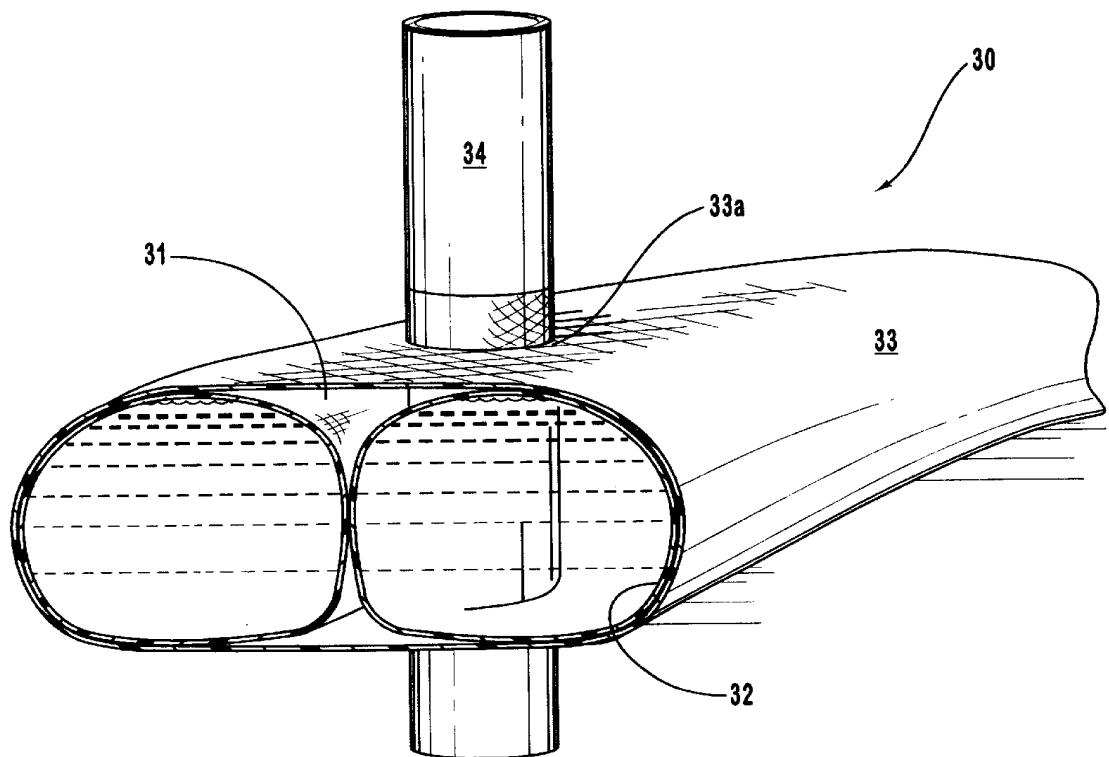

FIG. 5

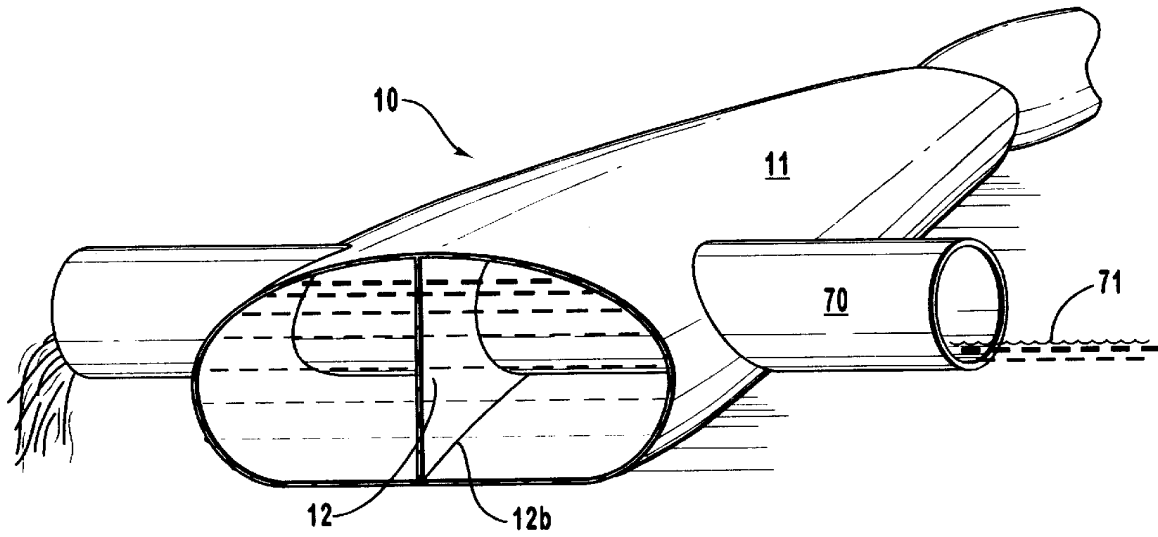

FIG. 5A

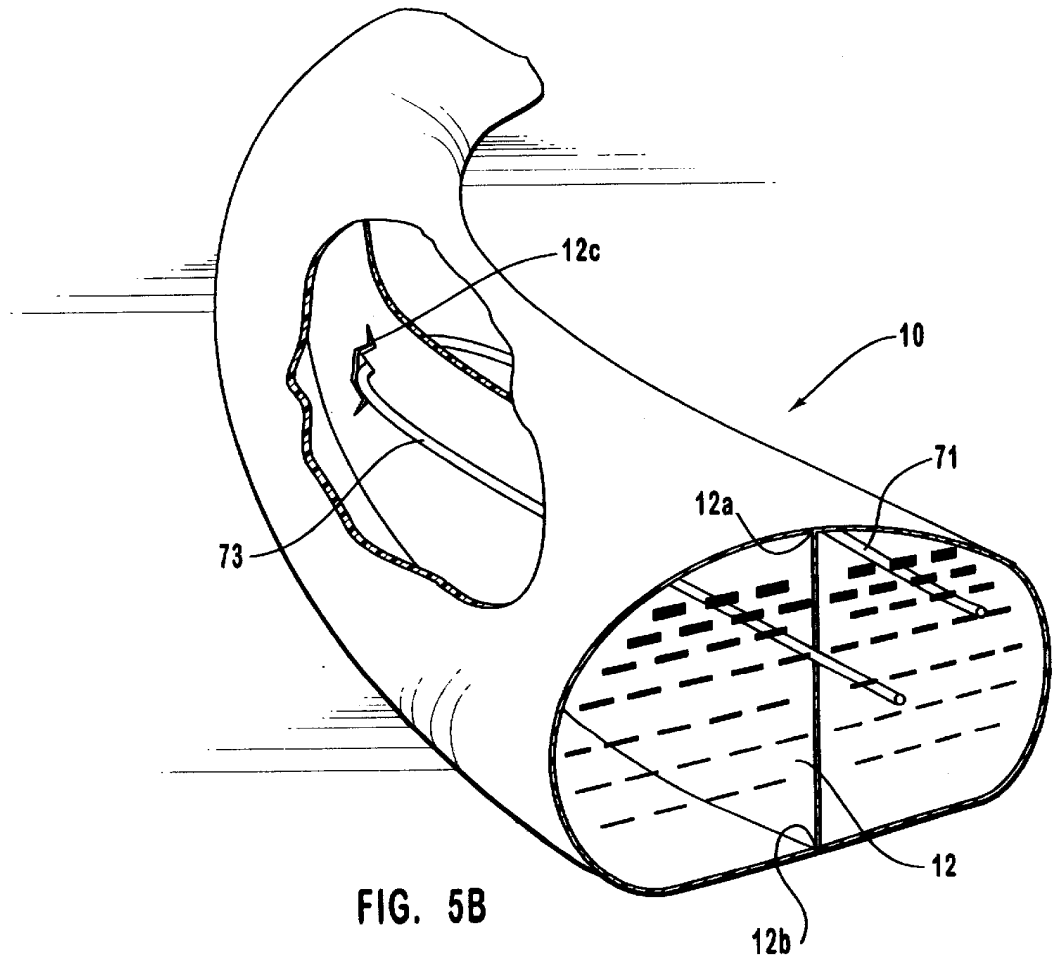

FIG. 5B

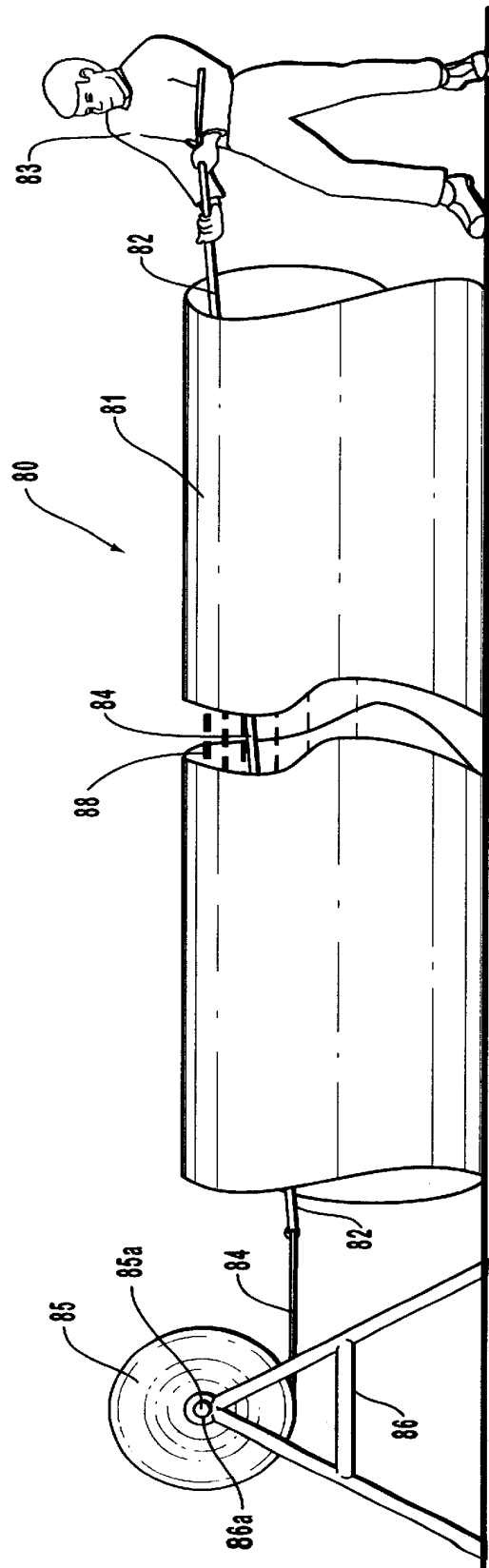

FIG. 5C

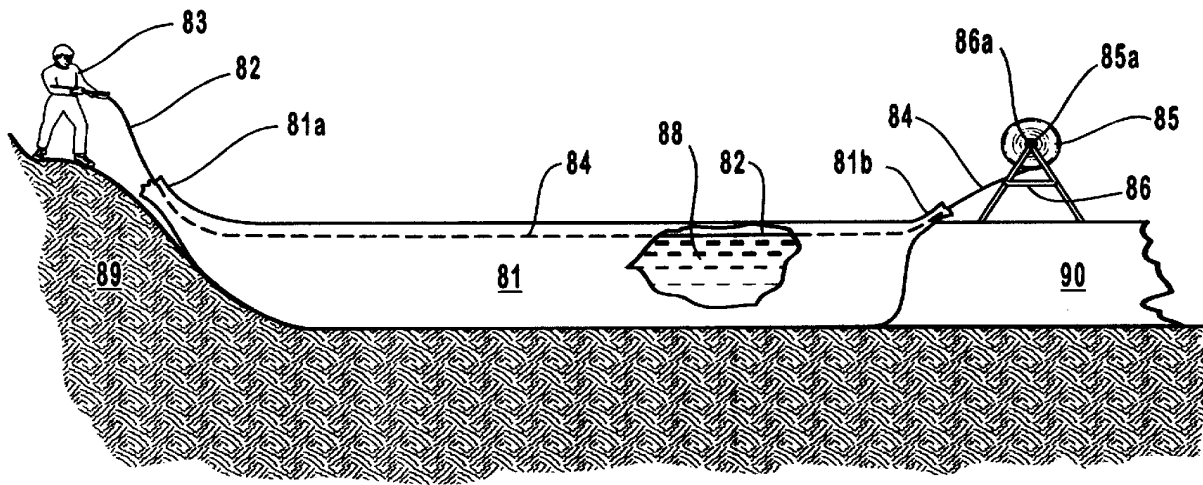

FIG. 5D

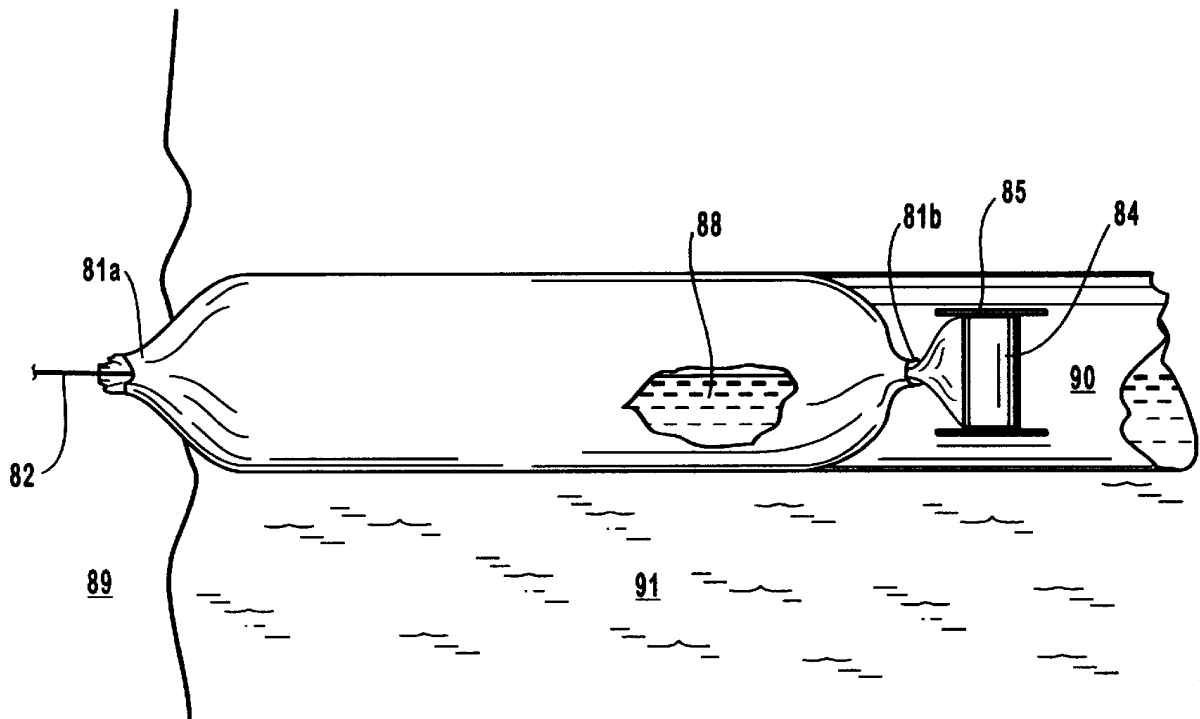

FIG. 5E

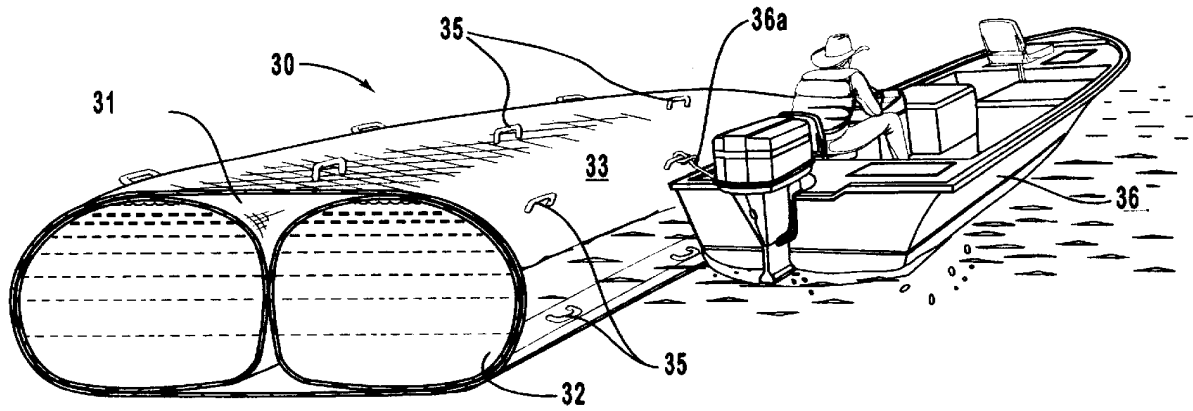

FIG. 6

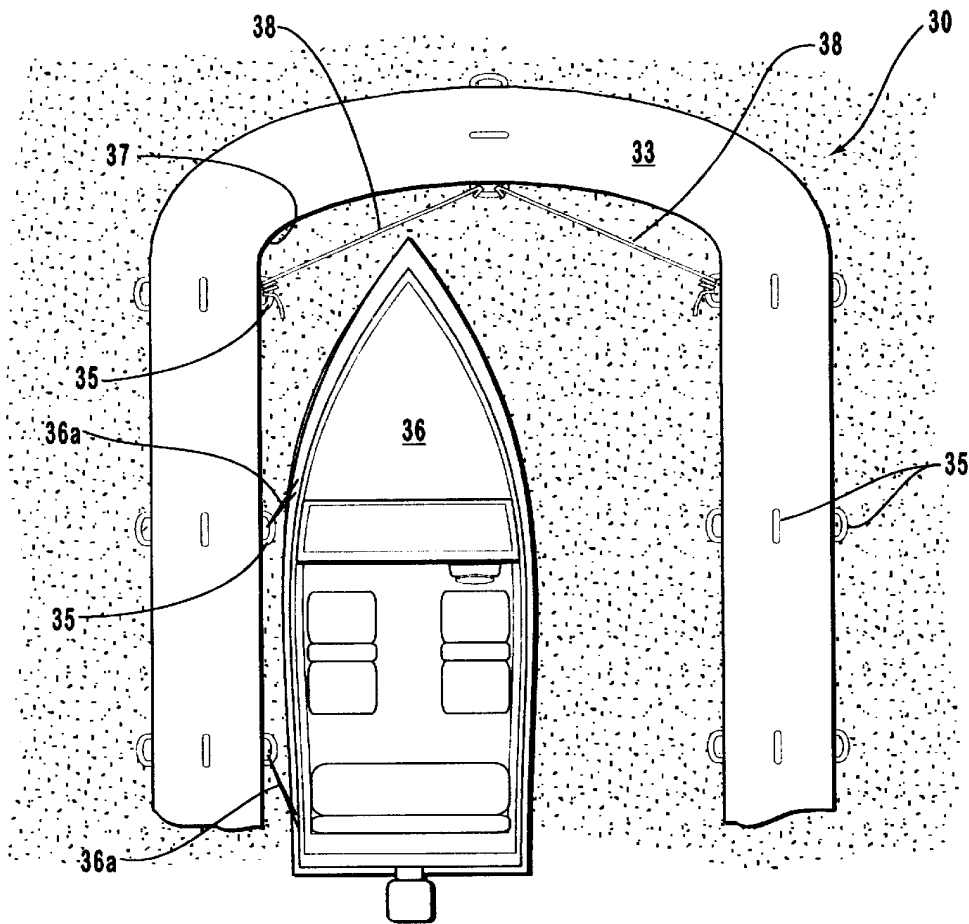

FIG. 7

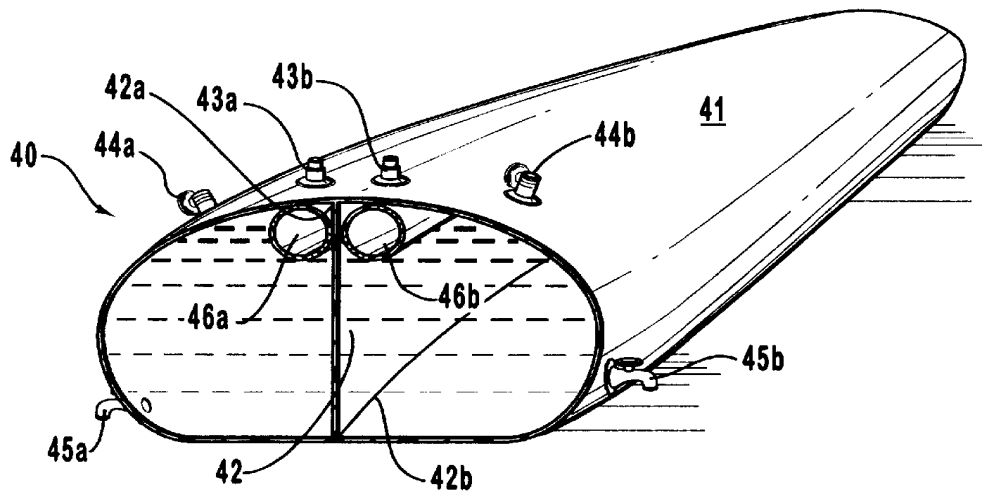

FIG. 8

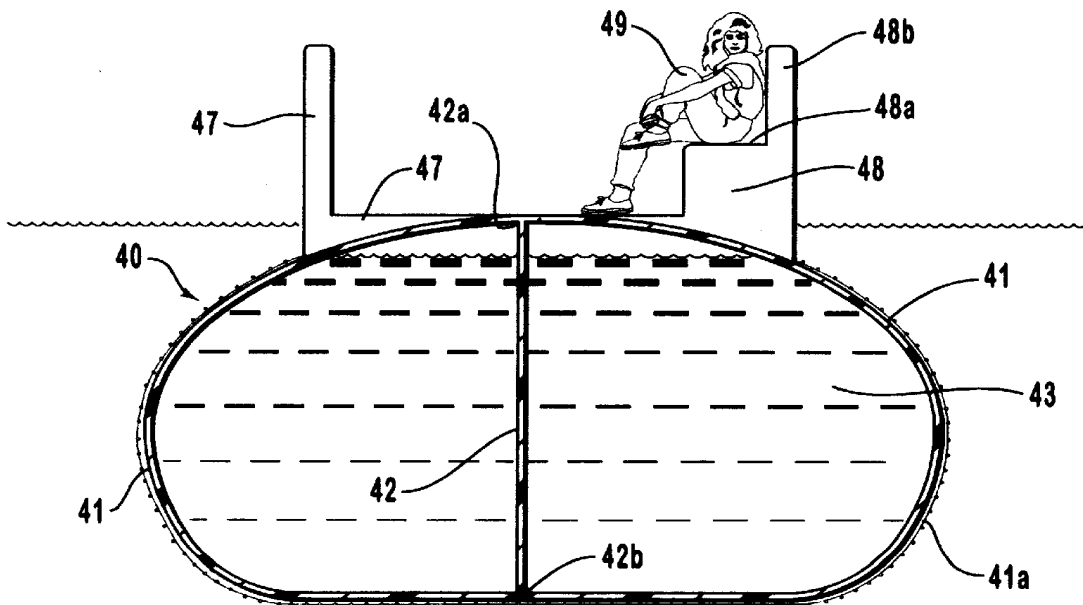

FIG. 9

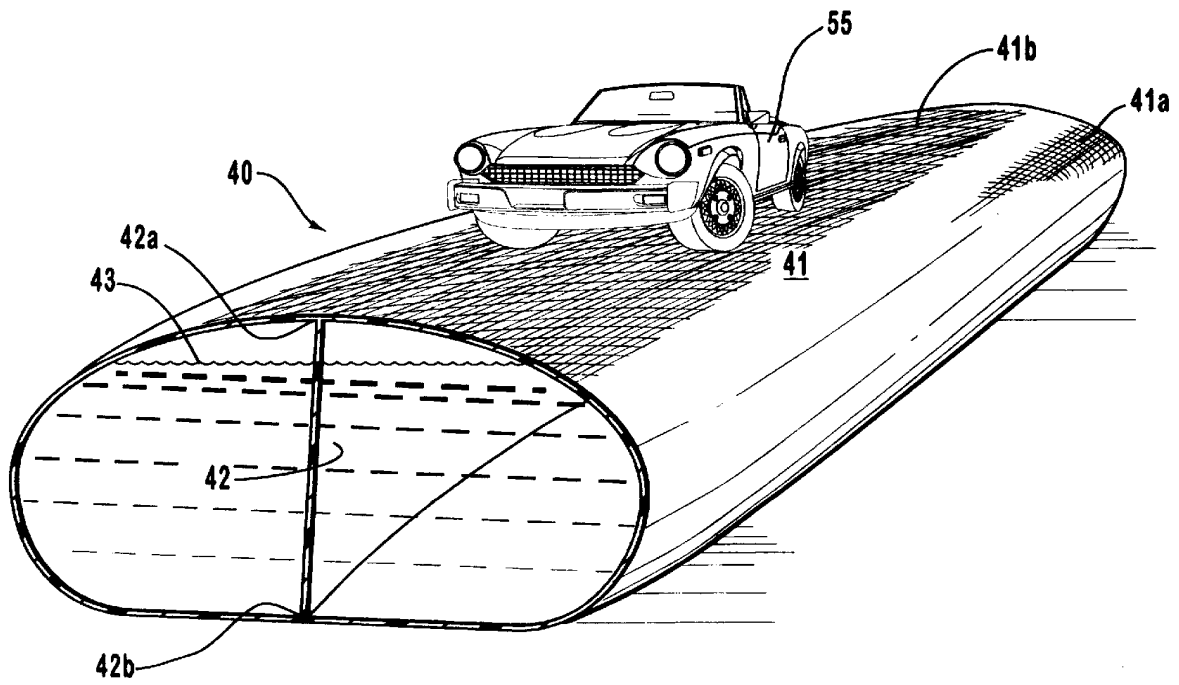

FIG. 10

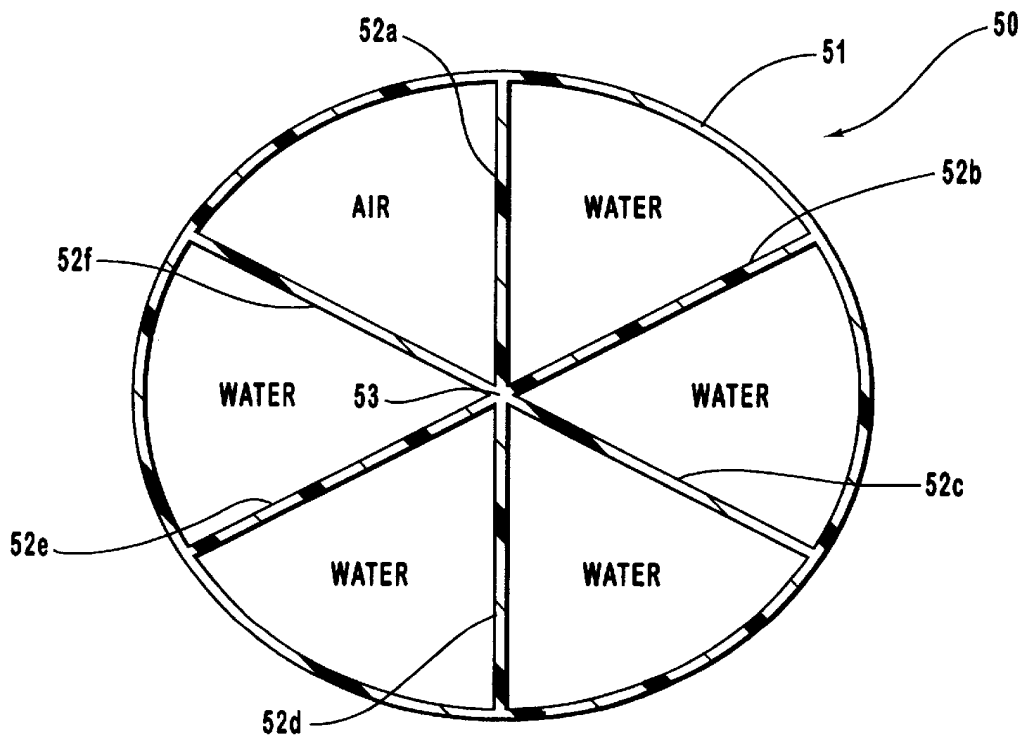

FIG. 11

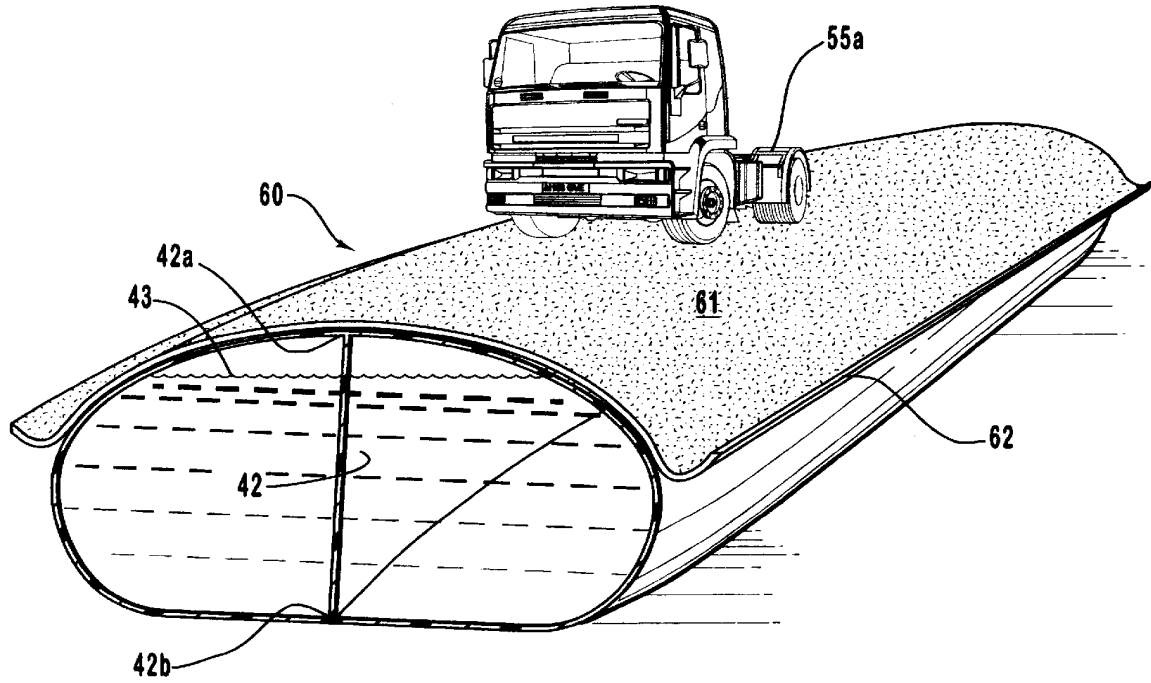

FIG. 10A

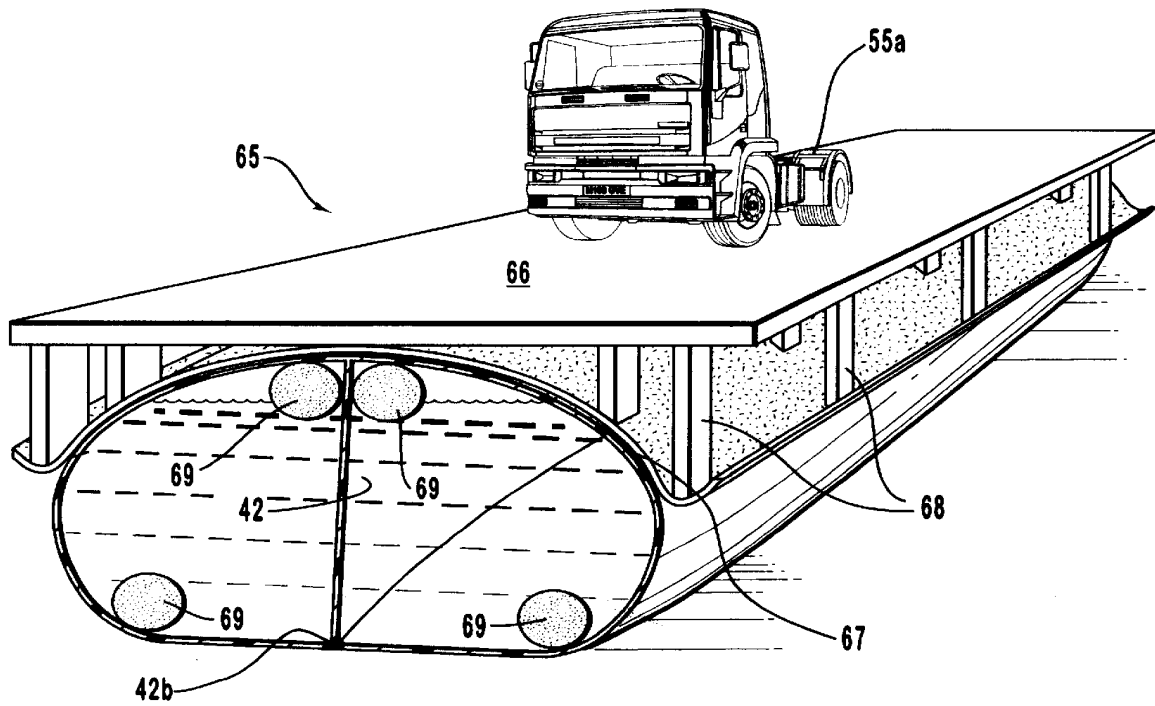

FIG. 10B

## FLEXIBLE HYDRAULIC STRUCTURE AND SYSTEM FOR REPLACING A DAMAGED PORTION THEREOF

### CROSS REFERENCES TO RELATED APPLICATION

The present application is a Continuation-In-Part Application of a Divisional Application Ser. No. 09/385,820 filed Aug. 30, 1999, now abandoned, that was derived from a parent U.S. patent application, Ser. No. 08/939,471, filed Sep. 22, 1997, now abandoned.

### PRIOR APPLICATIONS

This application is a Continuation in Part Application of a Divisional Application, Ser. No. 09/385,820, filed Aug. 30, 1999, from a patent application, Ser. No. 08/939,471, filed Sep. 22, 1997 now abandoned.

### BACKGROUND OF THE INVENTION

#### 1. Field of the Invention

This invention relates to structures for damming water courses, controlling water flow, working and support structures, and the like, and, in particular, is to provide a low cost and easily constructed tubular sleeve or envelope arrangement with divider or baffle walls, and/or multiple sleeves or envelopes with arrangements for maintaining the filled sleeves or filled envelopes together to form a variety of water filled structures.

#### 2. Prior Art

A need for easily installable dam structures, and the like, particularly structures that are relatively inexpensive, non-permanent, reusable and are durable has been early recognized by the inventor who has been awarded U.S. Pat. No. 's 5,059,065 and 5,125,767 for joining water structures together to form hydraulic damming structures, and the like. Such structures have been found to be very useful for safely and reliably containing or controlling water and are also particularly useful for controlling oil or chemical spills, for flood control, and the like. Such control structures are also useful, for example, for temporary damming operations such as may be involved in agricultural, construction, or like operations for de-watering work sites, fields, or the like, for use as temporary breakwaters, coffer dams, and the like.

Heretofore it has been recognized that fluid filled flexible control structures and barriers can be used for retention of water, control of water flow and wave action, and a number of configurations of dams and barriers formed as temporary structures have been developed. Additional to the U.S. patents of the inventor, some other such arrangements are shown, for example, in U.S. Patents to: Mesnager, U.S. Pat. No. 2,609,666; Mesnager, U.S. Pat. No. 3,246,474; Imbertson, et al, U.S. Pat. No. 3,355,851; Tabor, U.S. Pat. No. 3,834,167; Hombostel, Jr., U.S. Pat. No. 3,373,568; Hepworth, et al, U.S. Pat. No. 3,957,098; Suga, et al, U.S. Pat. No. 4,279,540; Muramatsu, et al, U.S. Pat. No. 4,299,514; Tsuji, et al, U.S. Pat. No. 4,314,774; Clem, U.S. Pat. No. 4,501,788; Paoluccio, U.S. Pat. No. 4,555,201; Holmberg, U.S. Pat. No. 4,690,585; Stevens, U.S. Pat. No. 4,784,520; and Brodersen, U.S. Pat. No. 4,799,821. The above show various containment, dam and barrier configurations ranging from permanent to portable structures, and include, as shown in Stevens and Brodersen, structures for encircling a chemical or oil spill. Further, a breakwater arrangement is shown in a U.S. patent to Sample, Pat. No. 4,729,691, that includes a plurality of sand filled bags that

are contained within an outer sleeve to serve as a barrier in an erosion control system. The above cited patents generally involve inflatable envelope arrangements that include some anchor structures therewith, and are generally restricted in that they don't rely on two or more bodies of water to form the structure and include anchors that must be permanently installed. Further, most such earlier arrangements require extensive site preparation and a number actually include a concrete bottom and sidewalls to provide for structure stability and barrier support thereby precluding their use as temporary water structures as provided by the present invention.

Summarizing, none of the above set out arrangements, provide, a simple barrier arrangement or arrangements of barriers that include filled or partially filled sleeves or envelopes with arrangements for anchoring the sleeves or envelopes, and which filled sleeves or envelopes can themselves support other structural elements to perform a number of functions as do the embodiments of the present invention. Where the above set out earlier patents of the inventor teach water containing sleeves or envelopes formed into a structure for arrangement as a dam, or the like, and a connecting sleeve arrangement for use with such water structures, neither of these patents involve the various arrangements for maintaining the water filled sleeves or envelopes together or for anchoring them along their lengths, or for their uses with other structures nor do such provide for a replacement of a damaged outer sleeve containing water by pulling a replacement sleeve therethrough, as does the present invention.

### BRIEF SUMMARY OF THE INVENTION

It is therefore a principal object of the present invention to provide a hydraulic structure that is formed from a section or sections of water filled sleeves, envelopes, or the like, that may be fitted together in end-to-end, or in intersecting relationship, for forming dams, breakwaters, piers, bridging structures, docks, platforms for drilling, and the like, where such formed structure will be stable even when subjected to a transverse hydraulic force or forces as would tend to move the structure.

Another object of the present invention is to provide a single or plurality of water filled sleeves, envelopes or the like, that are formed or connected to resist movement when a transverse or side hydraulic force, or the like is directed thereagainst.

Another object of the present invention is to provide, with a single sleeve as a water filled structure, a longitudinal center divider, longitudinal baffle, or spaces longitudinal baffles for discouraging or dampening a side load within the water filled sleeve as could be created by application of a transverse or side hydraulic load into the sleeve as could roll the sleeve.

Still another object of the present invention is to provide a sleeve, envelope, or the like that includes an arrangement for fitting a replacement sleeve or envelope into a damaged sleeve that contains water without a necessity to completely drain the damaged sleeve or envelope.

Still another object of the present invention is to provide a water filled structure formed from a single or number of sleeves, envelopes, or the like, with the single sleeve to include a dividing wall, baffle, or the like, and with the plurality of sleeves maintained together, with the structure arranged to be easily filled with water and includes drain and fill ports that are all conveniently and safely operated even in a desolate and/or unimproved area, which sleeves, envelopes, or the like, are easy to maintain, and can be installed with minimum to no site preparation.

The present invention is in at least one flexible sleeve or envelope arrangement or arrangements that can be closed at its ends to receive and retain a volume of water. Such single sleeve preferably includes a dividing wall or walls or other baffle arrangement to prohibit an applied transverse hydraulic force from rolling the water containing sleeve. The dividing wall can be formed to extend the length of the sleeve and is connected at longitudinal axis along the sleeve or envelope inner surface, dividing the sleeve into two or more compartments. Or individual wall sections can be secured along their opposite edges to the sleeve inner surface, with gaps or spaces left between the individual sections that then functions as baffles, or, alternatively a single longitudinal dividing wall having a plurality of holes or openings formed therethrough and can be secured to the sleeve inner surface, dividing the sleeve into two or more sections, to function as a baffle. Such single sleeve or envelope with dividing wall, walls or baffle arrangement can include inlet and exhaust valves, as needed, and can further include an air inlet or bleed valve arrangement, within the scope of this disclosure.

Additional to a single sleeve that is divided by a longitudinal wall, multiple walls, baffle, or baffles, the invention can include a pair or more of tubes sleeves or envelopes that are connected together as by an adhesive, hot weld, or the like, along shared surfaces to form a pair of connected containers that, when water filled, will resist rolling apart when a side or transverse or side hydraulic load or force is applied thereto. Such single sleeve pair of sleeves, or multiple sleeves can be connected end to end with like sleeve arrangements utilizing a coupling sleeve arrangement like that shown in my earlier U.S. Pat. No. 5,059,065, or the like. So arranged, a control structure is provided as for damming, de-watering operations or as a platform, that can include inlet and vent valve arrangements for passing water or air into and draining water and air from the individual sleeves. Also, an additional sleeve or envelope, sleeves or envelopes, can be provided to contain the multiple sleeves for maintaining the pair of bodies water filled sleeves or envelopes together, and such arrangement or arrangements can include additional structure such as, a vertical tube for use in drilling operations, or a horizontal tube to function as a culvert, buoyancy tube or tubes, to be filled with a buoyant material such as to provide buoyancy in water to the structure.

Additionally, a sleeve having a number or compartments formed therein to individually receive a buoyance material to provide a desired buoyancy in water for use as a dock, platform, roadway bridge arrangement, or like type structure, can be so arranged within the scope of this disclosure.

A preferred sleeve arrangement is an open sleeve or envelope that can be closed at its ends and is formed from an appropriate flexible material. The sleeve, envelope or sleeves or envelopes may be reinforced internally, or externally may be contained in an additional sleeve, and may include a mat or web material secured thereto, or the like. Further, the invention includes an arrangement for fitting as by pulling, or the like, a second sleeve or envelope through a damaged first sleeve or envelope, which sleeve replacement is conducted without a necessity for first draining the damaged sleeve or envelope. In practice a flexible polyethylene plastic or vinyl welded tube manufactured by Layfield Plastics, having a range of wall thickness of from ten (10) to twenty (20) millimeters has been used successfully for the invention, though, it should be understood, the invention is not limited to any particular sleeve or tube manufacture or

thickness, and can utilize sleeves of greater or lesser wall thickness, can include a further enclosing sleeve, and have a mat, of metal, fiber, glass or like secured thereto to provide reinforcement to the structure, within the scope of this disclosure.

#### DESCRIPTION OF THE DRAWINGS

In the drawings which illustrate that which is presently regarded as the best mode for carrying out the invention:

FIG. 1 is a frontal perspective view of a cross section of a single water filled tube, envelope, or sleeve forming a water structure of the invention, with the single tube or sleeve shown as including a divider that is longitudinally centered in the sleeve, separating it into two or more sections;

FIG. 2 is a view like that of FIG. 1 showing a single tube or sleeve of the water structure as including spaced sections that are secured across the tube interior wall as baffles;

FIG. 3 is a view like those of FIGS. 1 and 2 showing a single water filled tube or sleeve of the water structure as including a center divider that is like that of FIG. 1 except that it includes a plurality of spaced holes formed therethrough to function as a baffle;

FIG. 4 is a frontal perspective view like that of FIG. 1 only showing 1 pairs of tubes or sleeves of the water structure joined longitudinally along their common surfaces, and showing a second pair of tubes or sleeves connected end-to-end therewith through a connection arrangement;

FIG. 5 is a frontal perspective view of a cross section of a pair of water filled tubes or sleeves shown contained in a third sleeve of the water structure and showing a vertical open cylinder passed through the third sleeve and fitted between the pair of tubes or sleeves;

FIG. 5A is a view like FIG. 1 showing an open cylinder as having been passed through the water filled tube or sleeve and its center divider;

FIG. 5B is a view like that of FIG. 1 only showing a section of rope, cable, or the like passed through one section of the tube or sleeve, and across the center dividing wall and out of the other section, which rope or cable is for attachment to an item to be pulled through the tube or sleeve;

FIG. 5C is a side elevation view of a single first tube or sleeve shown as having had a rope, cable or the like fitted longitudinally therethrough and connected on one end to an end of a second tube or sleeve for use in pulling the second tube or sleeve through the first tube or sleeve;

FIG. 5D is a view like that of FIG. 5C only showing the first tube or sleeve as filled with water with a person shown standing on the side of a hill and pulling the rope that has been passed through the first tube or sleeve where to a second tube or sleeve is attached, and showing the second tube or sleeve being unrolled off of a roller that is mounted on an abutting end of a third water filled tube or sleeve;

FIG. 5E is a top plan view of the sleeves of FIG. 5D;

FIG. 6 is a frontal perspective view of a water structure that includes the pair of water filled tubes or sleeves contained in a third sleeve for use as a dock where the containing or third sleeve is shown as including a number of outside mooring cleats that each extend outwardly and are at spaced intervals from the third sleeve surface for use in mooring a boat thereto or for turning the water filled sleeves in a different direction;

FIG. 7 is a top plan view of the dock of FIG. 6 shown as having been formed into a horse shoe shape with a boat shown moored within the area between the horseshoe sides;

5

FIG. 8 is a view like that of FIG. 1 of the single water filled tube or sleeve water structure that includes a center dividing wall and further includes a pair of buoyancy tubes fitted therein:

FIG. 9 is an end elevation view of the water structure of FIG. 1 showing the water structure as having an open top portion for filling with air, Styrofoam, or the like, to provide buoyancy, and showing a deck structure maintained thereon;

FIG. 10 is a view like that of FIG. 9 only showing a roadway type tread as having been formed in the top surface of the tube or sleeve and showing an automobile resting thereon; and

FIG. 10A is also a view like that of FIG. 9 only showing a separate rigid shell maintained ad a roadway over the tube or sleeve top surface supporting a truck thereon;

FIG. 10B is also a view like that of FIG. 9 only showing the rigid shell onto the tube or sleeve top surface of FIG. 10B and including a flat deck mounted thereon and showing the tube or sleeve as including filled buoyancy tubes fitted through the tube or sleeve sections;

FIG. 11 is an end elevation view of a cross section of a single tube or sleeve of a water structure that includes a plurality of walls projecting outwardly from a location within the tube that connects to the tube or sleeve interior wall at intervals there around forming tube or sleeve segments that can be individually filled, as shown, with air, or other buoyancy material, or water, for providing a water structure having a desired configuration and buoyancy.

#### DETAILED DESCRIPTION OF THE INVENTION

FIGS. 1, 2, 3, 5B, 5C, 5D and 5E show a water structure 10 of the invention that is formed from a single water filled tube or sleeve 11, that is a sleeve formed from a section of a flexible plastic material that is open at opposite end, and is preferably a sleeve like that discussed and claimed in an earlier U.S. Patent of the invention, No. 5,125,767. Though, it should be understood, another sleeve structure, such as one manufactured from rubber or a rubberized material could be so used within the scope of this invention. The water filled tube or sleeve 11, and the other tubes or sleeves shown herein, are hereafter referred to as "sleeve" and can, as shown best in FIG. 1 and as sleeve 81 shown in 5D and 5E, be connected end-to-end to another such sleeve 11a in FIG. 1, and sleeve 90 in FIGS. 5D and 5E, by a connection arrangement, not shown, to form a water barrier. As appropriate, such end-to-end connection can be provided by a coupling sleeve like that of my earlier U.S. Pat. No. 5,059,065, or the like, within the scope of this disclosure. The sleeve 11, as shown in FIGS. 1 and 5B, and the sleeve 81, as shown in FIGS. 5D and 5E, may include, as an internal roll-prevention structure, a center longitudinal divider wall 12, shown in FIGS. 1 and 5B that is preferably a thin flexible material like that of sleeve 11, and is secured as by adhesive bonding, heat welding, or by a like procedure, along its parallel top and bottom edged 12a and 12b, extending across the sleeve 11 inner surface. It should be understood that, while a sheet of flexible material, preferably a plastic material can be so used, another material, such as a sheet of rubber or rubber like material could be used as the internal roll prevention structure, within the scope of this disclosure. The divider wall of FIGS. 1 and 5B, separates the sleeve into two (2) independent water body compartments that each extend the length of the sleeve 11, from end to end thereof. The two (2) water body compartments are preferably individually vented, shown as vent

6

ports 13a and 13b, as needed, and are preferably located adjacent to the divider wall 12 top edge 12a. Water can be passed into the individual compartments through inlet valves 14a and 14b, with water to be drained from the individual compartments through drains 15a and 15b, respectively. Alternatively, such water can be drained by opening an end of the sleeve 11.

FIG. 2 also shows a single sleeve 11 formed as a water structure 10 that, to resist rolling when subjected to a transverse or lateral hydraulic force directed into the sleeve 11 side, includes a plurality of wall segments 16 that are each secured, like the divider wall 12 of FIG. 1, at their opposite parallel edges 16a and 16b, to the sleeve inner surface, each divider wall extending across the sleeve interior. The segments 16, as shown in FIG. 2, are spaced apart from one another at intervals along the sleeve longitudinal center axis, forming individual baffles and are spaced to allow for a passage of water within the sleeve through the gaps or openings between which segments 16. So arranged, a transverse or lateral hydraulic force as is directed into the sleeve could create a transverse flow of water or wave across that sleeve that could tend to displace the sleeve, and cause it to roll, is inhibited and dampened by the segments 16. In operation, for filling and draining the sleeve 11 of FIG. 2, a single vent port 13c, inlet valve 14c and drain 15c only is shown, and, it should be understood one port only can be used for filling and draining and that the tube or sleeve can be opened at its end to receive or drain water therefrom.

FIG. 3 shows still another arrangement of a single sleeve 11 as a water structure of the invention. Shown therein, the sleeve 11, like that of FIG. 1, includes a longitudinal divider wall 17 that is secured to the sleeve inner surface along opposite divider wall parallel edges 17a and 17b. The divider wall 17, like the divider wall 12 of FIG. 1, divides the sleeve 11 into two (2) sections or water bodies. The divider wall 17, of FIG. 3 is, however, to function as a water body separator or baffle and accordingly includes a number of spaced openings 18 formed therethrough functioning like the water structure described hereinabove with respect to FIG. 2. Accordingly, like the sleeve 11 of FIG. 2, as water is allowed to pass freely between the two (2) sections, through the divider wall 17 holes 18, single vent port 13d, inlet valve 14d and drain 15d only are shown, or alternatively, the ends of sleeves could be open, not shown.

FIG. 4 shows a water structure embodiment 20 that is formed from at least two (2) separate sleeves 21 and 22, forming two columns or bodies of water, that are connected together along their common longitudinal surfaces 23 such that, when the sleeves are filled with water, the one sleeve or body of water will be stopped from rolling by the other sleeve or body of water when a side or transverse hydraulic load is directed onto the one sleeve or the other body of water. Like the water structure 10 of FIG. 1, the water structure 20 sleeves 21 and 22 of FIG. 4 can be connected end-to-end to sleeves 21a and 22a for forming, for example, a continuous water barrier, such as a dam. Which end-to-end connected may but is not required to be like that described above with respect to FIG. 1. Further, like the two sections formed by the divider wall 12 of the water structure 10 of FIG. 1, as the two (2) sleeves 21 and 22 of FIG. 4 are each self contained, each sleeve 21 and 22 can include its own vent port 24a and 24b, respectively, its own inlet valve 25a and 25b, respectively, a pair of drains, 26a and 26b can also be provided to each sleeve 21. Which individual sleeves can each utilize one port only, or water can be drained from a sleeve by opening a sleeve end.

In practice, the water structures 10 and 20, as set out and described above, are useful, for example, as water barriers,

such as dams, or to redirect water flow as flow channels, and the like, and accordingly the individual sleeves **11**, **21** and **22** are preferably formed from a sleeve material having sufficient wall strength to preclude its rupture when subjected to anticipated hydraulic forces. Accordingly, a preferred material as has been used in practice for a manufacture of the sleeves **11**, **21** and **22** is a flexible polyethylene plastic sleeve or vinyl welded tube, or the like, and such are manufactured by Layfield Plastics, having a range of wall thickness of ten (10) to twenty (20) millimeters, though, it should be understood, the invention is not limited to any particular manufacture of sleeve or tube or of a particular wall thickness, and other appropriate tubes or sleeves can be used within the scope of this disclosure. Further, as set out and discussed below with respect to FIGS. **9**, **10**, **10A**, and **10B**, a reinforcing material or structure, such as a web or mesh material, that is formed plate, deck, or the like, can be secured, as by bonding, or otherwise connected, to the sleeve outer or inner surface or sections thereof for lending strength or support thereto, as required, within the scope of this disclosure, and as discussed hereinbelow.

FIG. **5** shows still another embodiment of a water structure **30** that, like the water structure **20** of FIG. **4**, preferably includes a pair of water containing sleeves that are maintained together. Distinct therefrom, however, water structure **30** provides a third containing sleeve **33** for maintaining water filled sleeves **31** and **32** together. Which third containing sleeve **32** is to perform, essentially the same function as the bond **23** that is included between the shared surfaces of the sleeves **21** and **22** of FIG. **4**. The arrangement of the water structure **30** of FIG. **5**, it should be understood, is similar to that shown in my earlier U.S. Pat. No. 5,125,767, but, distinct therefrom, it further includes a work structure, support structure, connecting arrangement, or the like. One of which structures is shown in FIG. **5**, as an open vertical tube **34** that has been fitted through top and bottom holes **33a** formed in the containing sleeve **33**, with the tube passed between the water filled sleeves **31** and **32** or may be passed through one of the sleeves **31** and **32**.

FIG. **5A** shows a further use of a separate transverse open cylinder **70** that has been fitted through and sealed in opposite sides and divider wall **12** of the single sleeve or tube **11** of FIG. **1**. Which cylinder **70** is shown as conveying a flow of water **71** therethrough, functioning as a culvert.

For forming a water structure **10**, FIG. **5B** shows a further use of the tube or sleeve **11** of FIG. **1** that includes the divider wall secured to the tube or sleeve inner surface, along opposite wall edges **12a** and **12b**, forming parallel first and second sections, and includes a rope, cable, or the like, **73** fitted into the first section open first end and extends the length thereof to approximately the opposite first section end, as shown in FIG. **5C**. Thereat, the rope, cable, or the like, **73** is passed through an opening **12c** formed through the divider wall **12**, and is bent upon itself to travel back through the other or second section and out of the second section first end that is adjacent to the first section open first end. Which rope, cable, or the like, **73** can be used to pull a second sleeve or tube through the sections.

FIG. **5C** shows a tube or sleeve **81** of a water structure **80** that can be a single tube or sleeve, that has one or more dividing water bodies that are like that shown in FIG. **1**, or can be another configuration, and includes a rope, cable, or the like **82**, that is passed therethrough. The one end of which rope **82** is to be manipulated by an operator **83**, with the other rope end connected to an end of a second tube or sleeve **84** that is shown as a roll **85** that is wrapped around a rod **85a** to turn in a collar **86a** mounted across an apex of

a stand or frame **86**. In practice, the rope **82** is included in the first tube or sleeve **81** when it is filled in anticipation of problems developing with the first or primary tube or sleeve **81**, such as a punctured, or the like, and where it is preferred to fit a second tube or sleeve **84** through the first tube or sleeve. The rope **82** is positioned in the first tube **81**, extending out of both tube or sleeve **81** ends **81a** and **81b**, as shown in FIGS. **5D** and **5E**, prior to filling. Thereafter, should the second tube **84** need to be fitted therethrough, even with the tube or sleeve filled with water **88**, operators can open the first tube or sleeve ends **81a** and **81b** and maintain the ends above the water level in the first tube to prohibit outward water flow. To provide for maintaining the tube ends **81a** and **81b** in an elevated attitude, as shown in FIGS. **5D** and **5E**, the ends are lifted and anchored against a ground up-slope or on top of an abutting water filled tube or sleeve **90**, respectively. So arranged, after attachment of the rope end onto an end of the second tube or sleeve **84**, an operator **83** can pull rope **82** through the first tube or sleeve end **81b**, thereby fitting the second tube **84** through the first tube or sleeve **81**, whereafter the second tube is filled with water. During which installation of the second tube the water filled first tube or sleeve is to maintain its integrity as a water barrier, or as a component of a water barrier, as shown best in FIG. **5E**. Whereafter, with the ends of the water filled second tube or sleeve closed, water in the first tube can be allowed to leak out from the first tube or can be drained from the first tube while the second tube is filling. Thereafter, the first tube will function as a protective sheath or covering for protecting the second water filled sleeve **84**.

Water structure **30**, as shown in FIG. **6** includes a plurality of mooring cleats, shown herein as U shaped bars **35**, loops, or the like, that are woven or otherwise formed into material and are to extend out from the surface of the containing sleeve **33**. The mooring cleats are for tying up a boat **36** as by a rope **36a**. So arranged, the water structure **30** of FIG. **6** functions as a dock. Similarly, the water structure **30**, as shown in FIG. **7**, includes the containing sleeve **33** and mooring cleats **35**, shown as the U shaped bars of FIG. **6**, that extend therefrom, and showing the sleeve **33** bent into a horseshoe shape at bends **37**. The horseshoe shape, as shown in FIG. **7**, can be retained as by tying ropes **38** between mooring cleats **35**, and FIG. **7** further shows a boat **36** moored by ropes **36a** thereto that can accordingly be docked inside or outside the U shaped water structure **30**. This arrangement, of course, prepares for making and holding a turn in a water structure of the invention preventing water pressure from straightening the structure.

FIG. **8** shows still another embodiment of a water structure **40** that is like the water structure **10** of FIG. **1** in that it is arranged as a single sleeve **41** and includes a longitudinal center divider wall **42** secured along its parallel top and bottom edges **42a** and **42b** to extend across the sleeve inner surface. The divider wall **42** forms a pair of water body compartments or sections, that each may include vent ports **43a** and **43b**, with each compartment or section to be filled with water through inlet valves **44a** and **44b**, and or through the sleeve ends, and each compartment or section may include a drain **45a** or **45b**, respectively or may be drained through the sleeve ends. Distinct from the water structure **10** embodiment of FIG. **1**, the water structure **40** further includes at least one buoyancy tube, compartment, or the like **46a**, and preferably a pair of buoyancy tubes, compartments, sections or the like **46a** and **46b**, that are maintained within the single sleeve **41**. The buoyancy tubes **46a** and **46b** are to be filled with a buoyant material to include Styrofoam, air, or the like, to allow the water

structure **40** to float in water as a dock, or the like. For stability, the buoyancy tubes **46a** and **46b** are preferably located adjacent to the junctions of the divider wall top edge **42a** with the single sleeve **41** inner surface, as shown.

FIG. **9** shows the water structure **40** less the buoyancy tubes **46a** and **46b**, and therefore is essentially the water structure **10** of FIG. **1**. The water structure **40** of FIG. **9**, however, like that of FIG. **8**, is intended to be able to float and accordingly is preferably arranged to receive air, or other buoyancy material, passed therein shown as a volume of air above the layer **43** of water that is contained therein, or may be Styrofoam or air filled, or may be filled with another buoyant material, within the scope of this disclosure. A volume of air, or other buoyant material, can be introduced therein through the inlet valves **44a** and **44b** or the vent ports **43a** and **43b**, of FIG. **8**, within the scope of this disclosure. Shown in FIG. **9**, the water structure **40** is arranged for use as a dock or wharf to include a deck **47** that is accordingly maintained on a water structure top surface, above the layer of water **43** therein. As shown, the deck can include a fence **47a** secured to extend upwardly from along one deck edge with a seat **48** having a horizontal portion **48a** and a vertical portion **48b** secured along the other deck edge. The seat or fence, for illustration purposes, that can be filled with water, air or ridged material, and is shown as having a person **49** seated thereon, or another arrangement can be so provided for use as a permanent or semi-permanent structure. To add strength and durability to the water structure **40**, an outer sleeve **41a**, that is shown formed as a mat or ribbed surface is preferably secured over the sleeve **41** outer surface, adding strength thereto, providing a damage resistant surface, or can even include a slippery surface for use as a slip and slide, or the like, within the scope of this disclosure.

FIG. **10** shows the water structure **40** of FIG. **9** less the deck **47** that has been replaced with a support surface **41b** formed as by bonding it over the top surface of the single sleeve **41** whereon a vehicle **55** is shown resting. The water structure **40** of FIG. **10** can be arranged as a bridge, dock, or the like, to support vehicle travel thereover. Accordingly, it should be understood, the support surface **41b** is preferably provided for reinforcing the structure and such may be formed from a mat, or the like, of a strong material that is bonded thereto to resist wear. Such reinforcing surface **41b** may be a fabric or metal, may be formed as a sleeve to contain the inner sleeve **41**, and its bond to the sleeve surface may be an epoxy, or like adhesive, within the scope of this disclosure. Like the water structure **40** of FIG. **10**, a water structure **60** is shown in FIG. **10A** that includes a cap **61** fitted along its top surface that is preferably a rigid strong material, such as metal or fiberglass, and is secured thereto. Like the water structure **40** of FIG. **10**, the water structure **60** of FIG. **10A** can provide a roadway for supporting a vehicle **55a**, for example, traveling therealong. Additionally, as shown, the cap **61** preferably includes upturn edges **62** along the cap opposite longitudinal sides that are for use, as for example and as shown in FIG. **10B**, for anchoring support members, and will also reduce wear when the water structure is moved under wave action.

FIG. **10B** shows a water structure **65** that is like the water structure **60** shown in FIG. **10A** to include the cap **61** with upturned edges **62** that is secured to a top surface of tube or sleeve **41** and additional includes a flat deck **66**, that is formed from a rigid material and is supported on spaced inner and outer posts **67** and **68**, respectively, that are shown secured at their ends to the cap **61** top surface and along the cap edges **62**, respectively. So arranged, the respective post **67** and **68** tops are secured at right angles to the flat deck **66**

undersurface with the deck maintained essentially parallel to the surface whereon the tube or sleeve **61** rests, to support a vehicle, shown as a truck **55a**, or the like, thereon.

Additionally, the water structure **65** is shown as included buoyancy tubes **69** that are secured within the tube or sleeve **41**, to extend longitudinally therein and are spaced apart from one another. The buoyancy tubes **69** can be filled with any buoyant material such as air, Styrofoam, or the like within the scope of this disclosure and are preferably arranged in the compartments or water body sections as are formed by divider wall **42** to be equidistant from the divider wall to provide an equal or balanced buoyancy across the tube or sleeve **41**.

Where the water structure **40** of FIGS. **9** and **10**, and water structures **60** and **65** of FIGS. **10A** and **10B**, are shown for use for supporting human and vehicle traffic, functioning as a dock, bridge, or the like, it should be understood that, to safely perform such functions, the single sleeve will preferably be formed from a tough and durable material or may be capped, as shown, or may be surrounded with such tough and durable material. Accordingly, a material for single sleeve **41** will preferably be selected to have appropriate strength with wear resistance characteristics and may, as required, be reinforced as by bonding two or more sleeves together, applying a reinforcing mesh or weave of material to the sleeve surface that may be applied along a sleeve top surface **41b** as shown in FIG. **10**, or may be formed as a full cylinder to encase the inner sleeve, within the scope of this disclosure. Which material that can be cloth, metal or the like, or like reinforcing arrangement attached as by adhesive bonding can be so employed, within the scope of this disclosure.

Another embodiment of a water structure **50** is shown in FIG. **11** as consisting of a single outer sleeve **51** that can have a round cross section, as shown by may have other shape, such as a square, so long as such sleeve **51** is appropriated for used within the scope of this disclosure. The single sleeve **51** can be reinforced as by fitting two or more sleeves together, one within the other, by securing a reinforcing material thereto, or the like, as set out immediately above, and preferably includes a plurality of divider walls **52a**, **52b**, **52c**, **52d**, **52e** and **52f** secured together within sleeve **51**, such as at the sleeve longitudinal axis **53**, that may but need not be the sleeve longitudinal center axis, as shown. Each divider wall is to extend radially from the longitudinal axis **53** and is bonded, along its outer edge, to the single sleeve **51** inner surface forming individual compartments or sections or formed from many tubes or sleeves that are for containing, as shown, water, air, or other material as desired to provide a desired buoyancy in water to the water structure **50**. Such individual compartments or sections could, of course, include inlet and drain arrangements like those set out hereinabove though, of course, a single valve for each compartment or section can be so provided that is capable of use for both filling and draining the individual compartments or sections, or the sleeve can be opened at its end or ends to drain water therefrom, within the scope of this disclosure. Like the water structures **40** set out and described hereinabove with respect to FIGS. **8** through **10**, and water structures **65** and **70** of FIGS. **10A** and **10B**, and the water structure **50** can be configured to be supported in water for use as a dock, breakwater, bridge, cause way, or the like, and when filled with water can perform the water retaining functions set out and described hereinabove with respect to the water structures **10**, **20** and **30** of FIGS. **1** through **7**.

Although preferred embodiments of the invention have been shown and described herein, it should be understood

11

that the present disclosure is made by way of example only and that variations are possible within the scope of this disclosure without departing from the subject matter coming within the scope of the following claims and reasonable equivalency thereof, which claims I regard as my invention. 5

I claim:

1. A water structure comprising, first and second flexible tubes or sleeves that can be closed at their ends, each forming a vessel; a roll-prevention structure maintained with said first flexible tube or sleeve; one or more filling means 10 for filling each of said flexible tubes or sleeves with water; and further including a rope for arrangement through said first flexible tube or sleeve before filling the first flexible tube or sleeve with water, and said rope is arranged for attachment to an end of said second flexible tube or sleeve, 15 whereby, when said rope is pulled out from an end of said first flexible tube or sleeve containing a significant volume of water, said second flexible tube or sleeve travels through, to function as a liner for, said water filling said first flexible tube or sleeve.

2. The water structure as recited in claim 1, wherein the ends of the first flexible tube or sleeve are maintained above the level of water in said first flexible tube or sleeve; and the rope is positioned within and extends out through both of the ends of said first flexible tube or sleeve.

12

3. The water structure as recited in claim 1, wherein the first flexible tube or sleeve includes a dividing wall that forms, in said first flexible tube or sleeve, adjacent, parallel, first and second sections; and the rope extends the length of said first flexible tube or sleeve inside of said first flexible tube for sleeve, from a first open end of the first section, and passes through a spaced opening through said dividing wall and is bent back to travel along the length of the second section, alongside of said dividing wall and emerges from said first open end of said first flexible tube or sleeve.

4. The water structure as recited in claim 1, further including the second flexible tube or sleeve is rolled onto a straight rod whose opposite ends are journaled onto collars secured between sides of a frame, with said rod to turn, unrolling said second flexible tube or sleeve off therefrom; and an end of the rope is attached to the end of the second flexible tube or sleeve and with the first flexible tube or sleeve ends maintained above the level of water in said first flexible tube or sleeve, by pulling said rope from one of the 20 first flexible tube or sleeve ends, said second flexible tube or sleeve unrolls off of said rod and travels through said first flexible tube or sleeve as a liner for said first flexible tube or sleeve.

\* \* \* \* \*