



(19) **United States**

(12) **Patent Application Publication** (10) **Pub. No.: US 2017/0241092 A1**

Doolaege

(43) **Pub. Date: Aug. 24, 2017**

(54) **WATER CONTAINMENT STRUCTURE WITH FINGER ENDS**

(71) Applicant: **David Doolaege**, Cariotta, CA (US)

(72) Inventor: **David Doolaege**, Cariotta, CA (US)

(21) Appl. No.: **15/047,209**

(22) Filed: **Feb. 18, 2016**

Publication Classification

(51) **Int. Cl.**
E02B 3/10 (2006.01)

(52) **U.S. Cl.**
CPC **E02B 3/108** (2013.01)

(57) **ABSTRACT**

A water containment structure that includes at least one flexible sleeve formed from a strong flexible material that will resist puncturing and is formed to contain at least one bladder formed to retain water, and which said sleeve includes center notches formed in the opposite sleeve ends that separate like closed end parallel fingers, which bladder fills the sleeve to the sleeve finger ends so that the bladder ends fit into and against the finger ends, and at least one water fill and drain tube fitted through said sleeve into said bladder to pass, respectively, water into, and drain water from which bladder, and said bladder includes an air drain to provide for evacuating air from the sleeve during bladder filling. Which sleeve finger ends can be fastened together around a support, and which sleeve finger ends and notches can be secured to one another for connecting a number of sleeves, end to end, into a water containing structure.

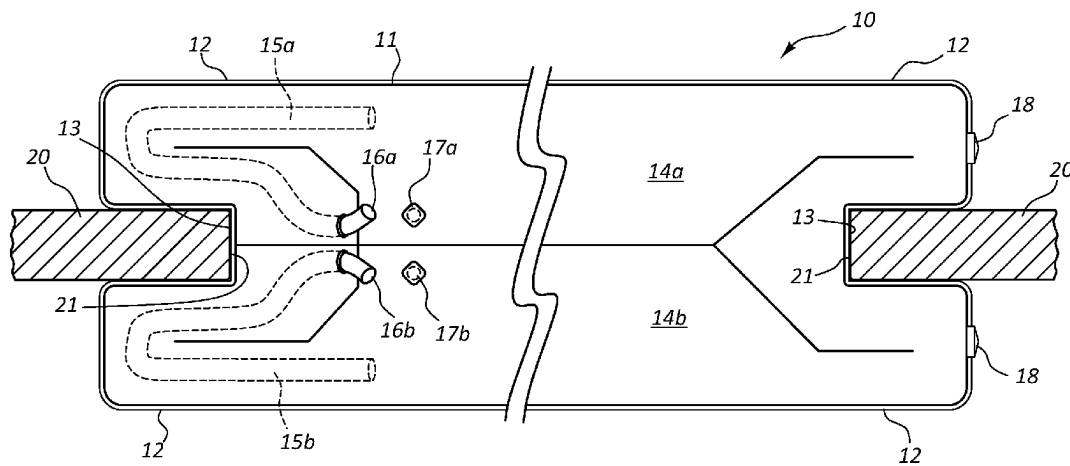

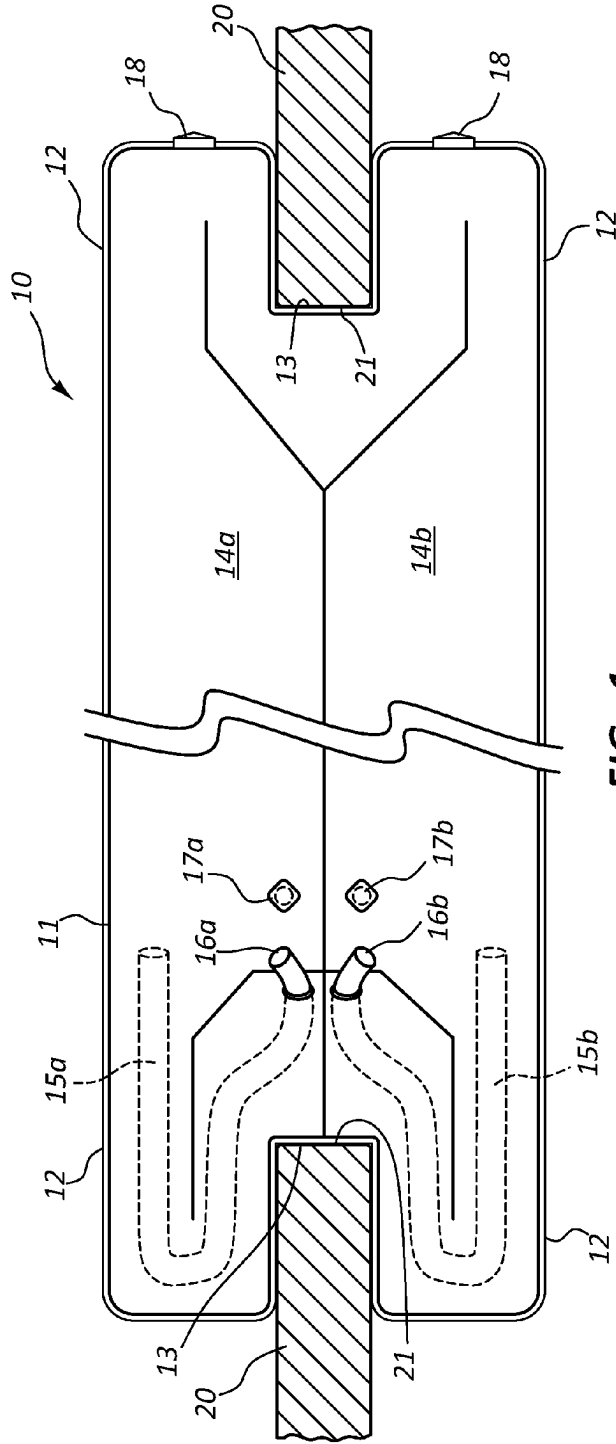

FIG. 1

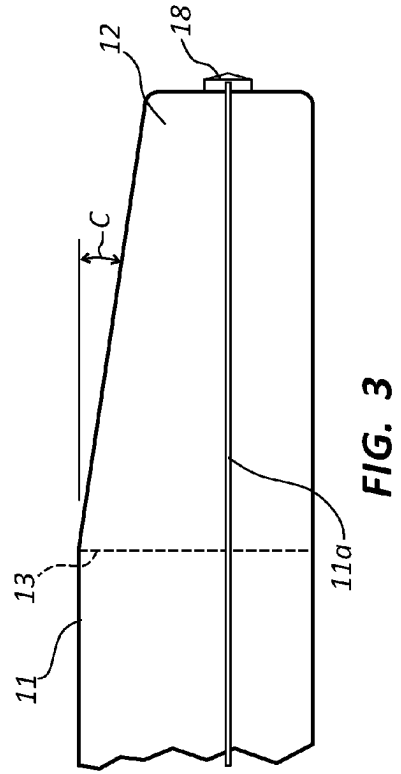

FIG. 2

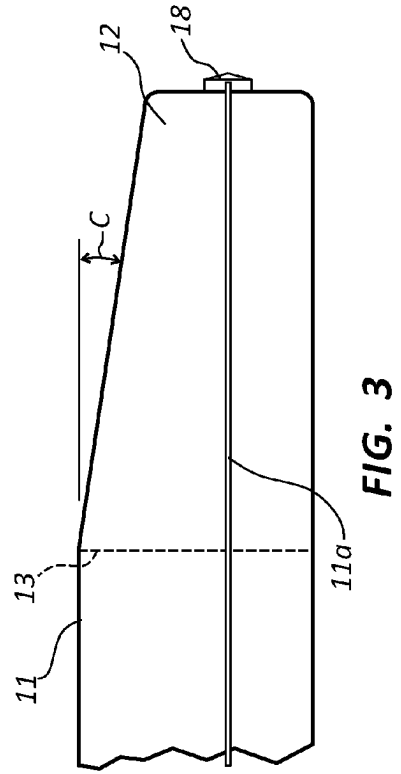

FIG. 3

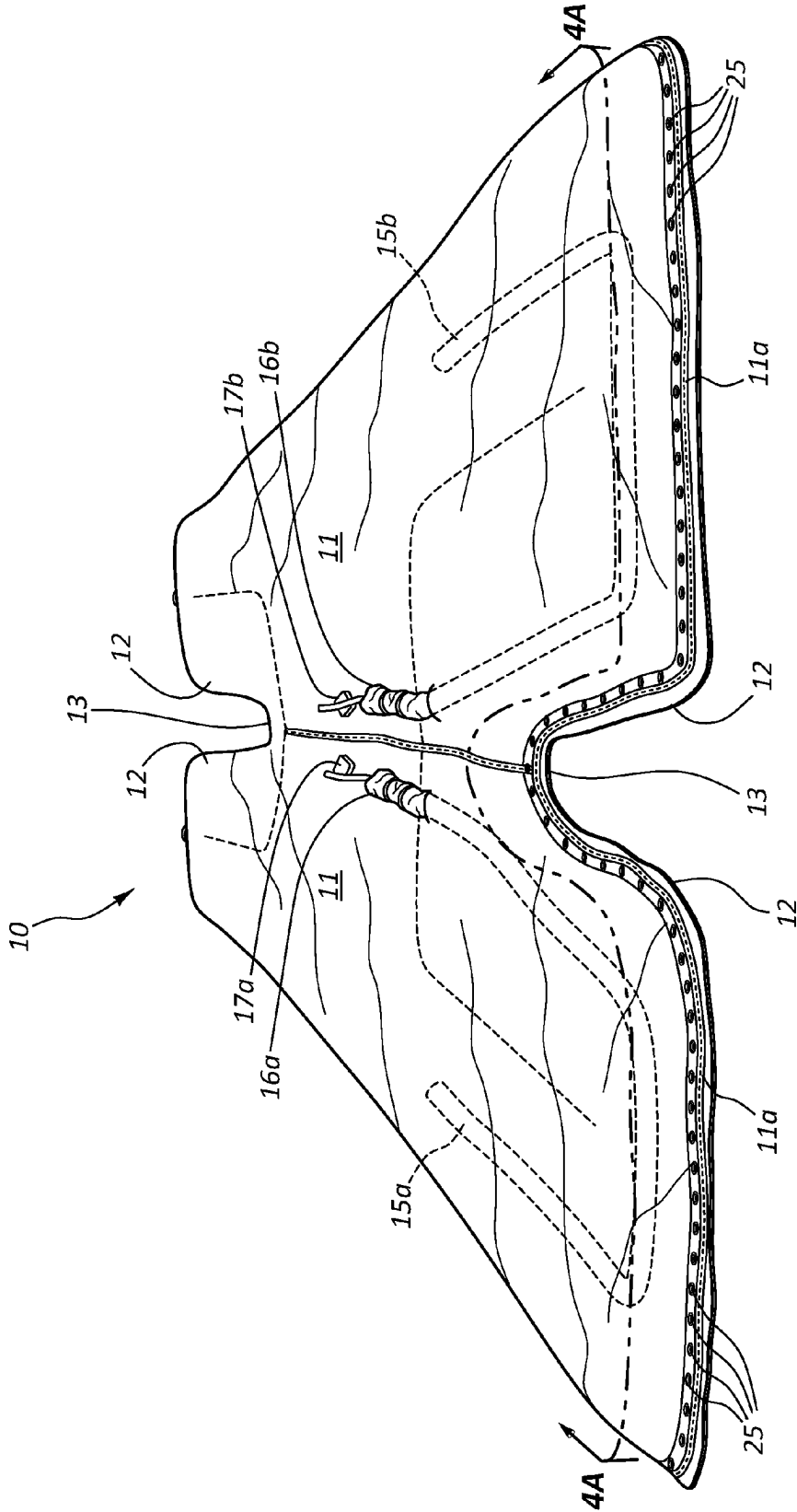

FIG. 4

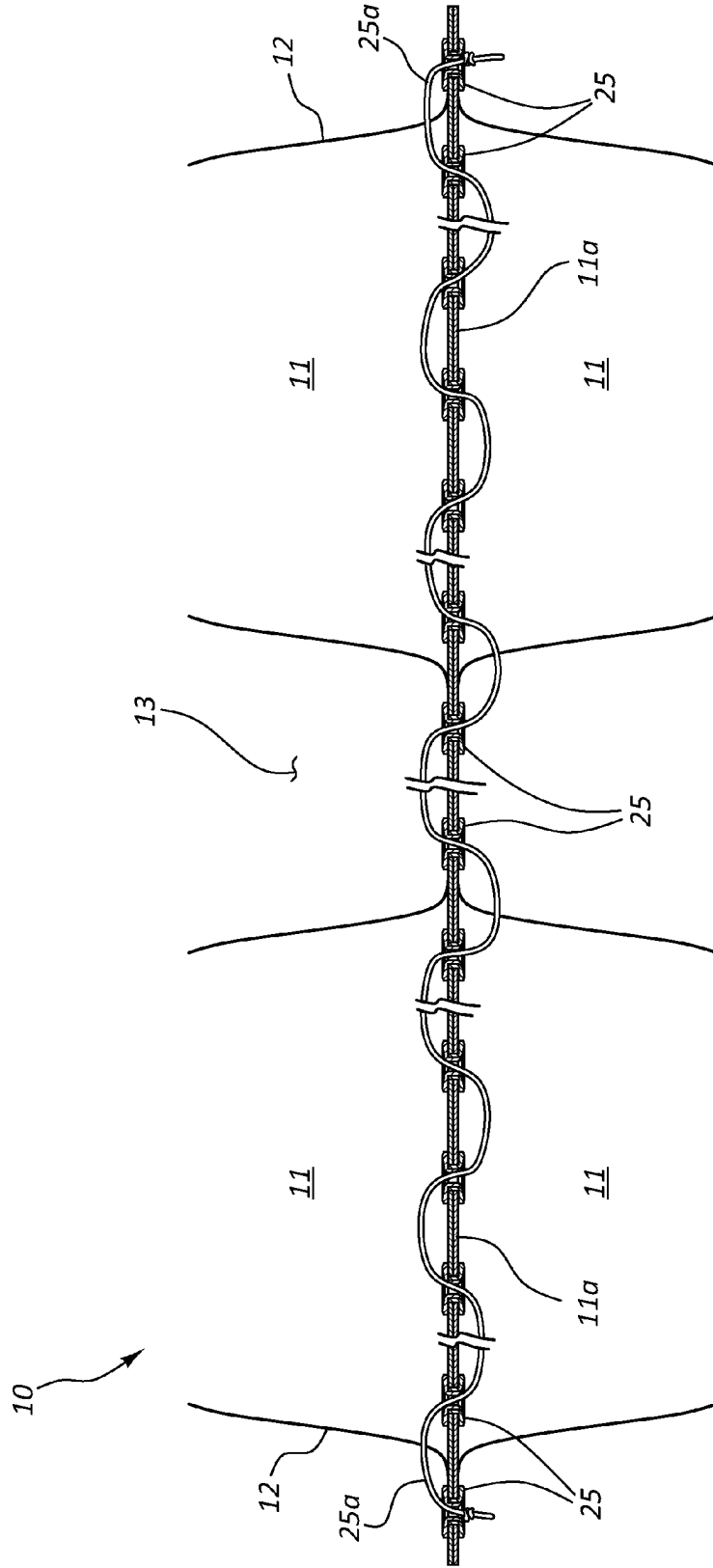

FIG. 4A

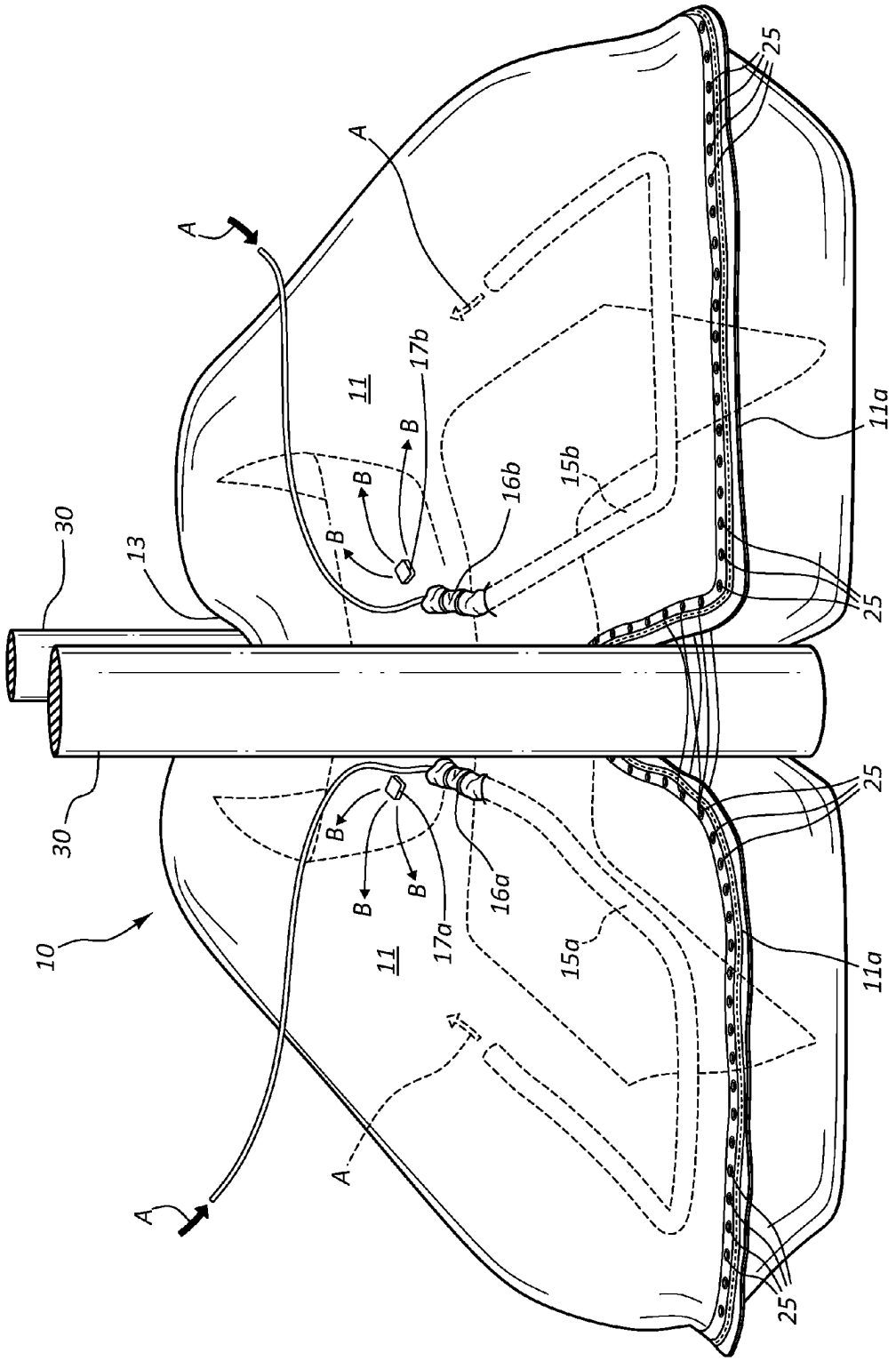

FIG. 5

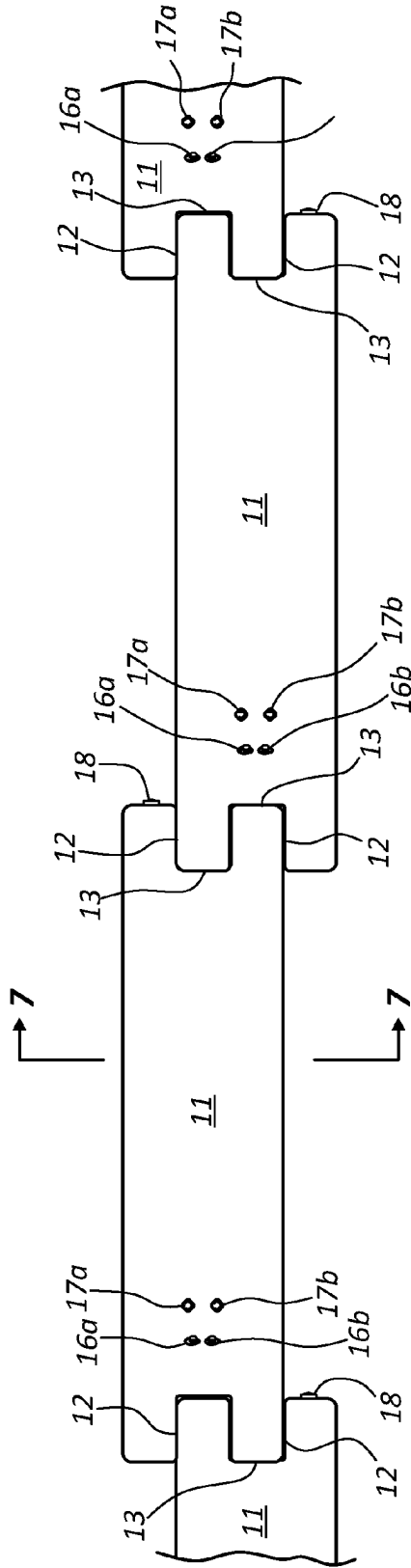

FIG. 6

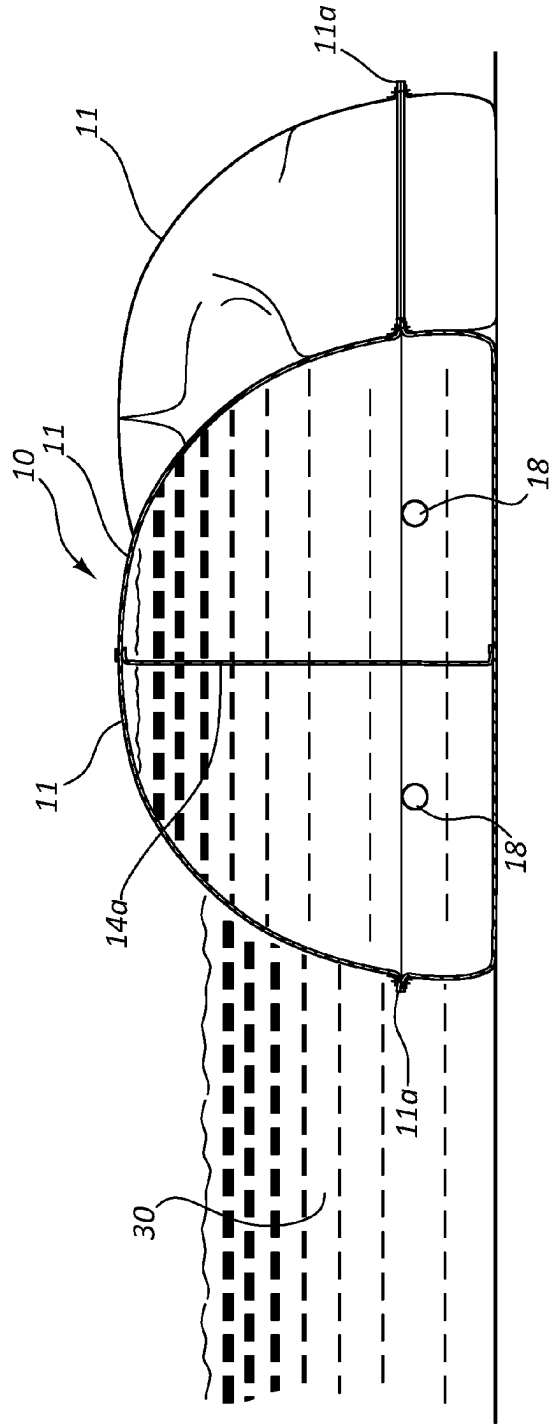

FIG. 7

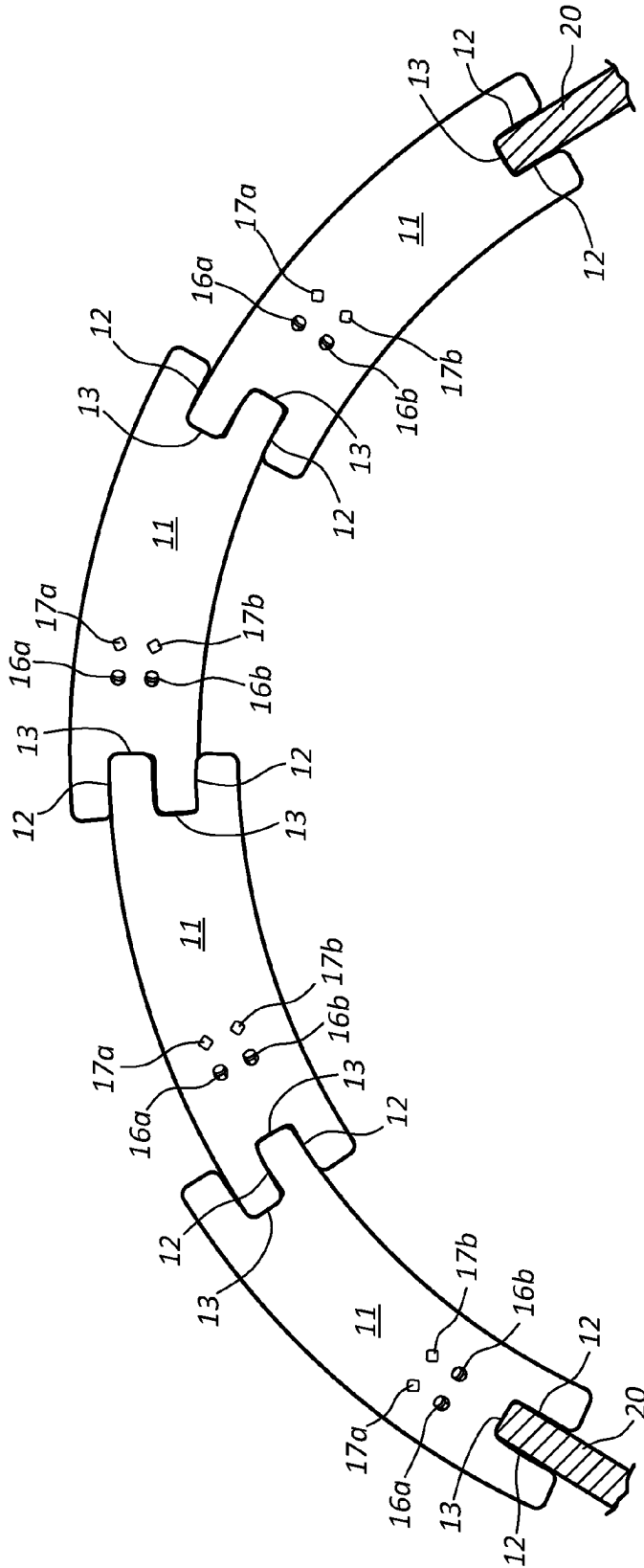

FIG. 8

WATER CONTAINMENT STRUCTURE WITH FINGER ENDS

[0001] This application is a Continuation in Part application of application Ser. No. 14/262,758, for a “WATER CONTAINMENT STRUCTURE WITH FINGER ENDS” filed Apr. 27, 2014, that is abandoned with the entry of this Continuation in Part application.

BACKGROUND OF THE INVENTION

Field of the Invention

[0002] This invention relates to temporary structures for filling with water for damming water courses, controlling and directing water flow, for damming between walls and support structures, and providing for end to end connection of structures to extend across an area to be dammed, and the like, and includes sleeves for containing water containing bladders, where the damming structure is inexpensive to construct, erect, and dismantle.

PRIOR ART

[0003] A need for easily installable and versatile water containment structure, and the like, particularly structures that are easily installed by filling them with water, that are relatively inexpensive, non-permanent, reusable and are durable, have been recognized by the inventor who has been awarded a number of U.S. patents for forming and joining water structures together, forming hydraulic water containment structures. Such water containment structures have been found to be very useful for safely and reliably containing water, for directing and controlling water, are also useful for controlling hazardous waste, oil or chemical spills, and the like. Further, such water containment structures are also useful, for example, for temporary damming operations, such as may be involved in agricultural water storage, construction, for de-watering work sites and fields, to protect buildings against flooding, and the like, and are even appropriate for use as permanent or long term water containment structures.

[0004] Heretofore it has been recognized that fluid filled flexible water containment structures and barriers can, if formed to resist movement, be used for retention and storage of water, control of water flow and as barriers against wave action, and a number of configurations of dams and barriers have been arranged as both semi-permanent and temporary structures. Such earlier patents, however, do not show a combination of a flexible sleeve that is configured with like finger ends, where the sleeves can be fitted and maintained together to form a continuous water containment structure, or where the finger ends can be fitted across a door way, or against a wall end, to span that door way or wall. In practice, with the filling of a bladder or bladders within the sleeve or sleeves, a secure water containment structure is formed.

[0005] Where earlier water containment sleeve and bladder structures have been arranged across an area to be dammed or de-watered, such have generally included pairs of sleeves with bladders that are braced against a pier structure, or have employed an outer sleeve to discourage the individual interior sleeves and filled bladders from rolling apart responsive to the weight of water or wave action that have been directed against the water containment structure, or have utilized other arrangements for keeping the sleeves with water filled bladders from moving. Unique

to the invention, the sleeve fingers can be joined together, as by lacing them together along common edges, to discourage sleeve movement, can be joined around a fixed pole, or the like.

[0006] Summarizing, before the invention, no prior art water containment structure has provided a barrier arrangement or arrangements of barriers with the like sleeve ends have fingers to function, as set out above, to provide a versatile water containment structure that will meet a variety of needs as the invention can be used for.

SUMMARY OF THE INVENTION

[0007] It is a principal object of the present invention to provide a water containment structure that includes at least one flexible sleeve for containing a bladder or bladders for filling with water, where each bladder includes a filling arrangement and an air drain, and where the sleeve or sleeves have like finger ends separated by a center U shaped notch that the bladder or bladder ends fit into, and each said sleeve end includes an air vent for venting air during filling of the bladder or bladders with water, and the sleeve ends notches are arranged to be fitted together, alongside one another on opposite sides of the edge of a doorway or wall, to provide, when the bladder or bladders are filled with water, a barrier to contain, or block, a volume of water, and which sleeve notched ends, when fitted together where the opposing sides of each notch are in contact and can be maintained together to form a continuous barrier across an area to be de-watered, or protected from flood waters.

[0008] Another object of the present invention is to provide sleeve ends, from adjacent to the sleeve notches to finger ends, with flat parallel top and bottom surfaces, or can form each sleeve finger to have a taper in the top from adjacent to, or forward from, the notch, to the finger end to facilitate positioning of the sleeve finger ends, containing the bladder ends, across a door way or wall, and for, with blunt sleeve finger ends fitted together, provide approximately a uniform height of the water containment structure. across the notches.

[0009] Another object of the present invention is to provide sleeves having ends formed as fingers with a notch therebetween, where the finger ends can be fitted around or across a fixed structure such as a door way, wall, post, or the like, and provides for joining the sleeve fingers around such post, as by lacing the fingers ends through spaced holes formed along the notch and fingers edges, to fix the sleeve ends in place, whereafter, the bladder or bladders in the sleeve are filled with water to provide a barrier to water.

[0010] Still another object of the present invention is to provide for; conveniently filling each bladder with water to erect the structure as a water barrier; and provides for venting air from the bladder or bladders during filling; and for conveniently draining which bladder or bladders to deflate the barrier when it is no longer needed.

[0011] Still another object of the present invention is to provide a portable water containment structure that is easily transported and erected at a site to protect a building against flooding, prohibit flooding of an area, or for de-watering a flooded area, that is easily deflated and removed after the water danger has subsided.

[0012] Principal features of the invention include at least one sleeve that is formed from a strong, woven polypropylene material, such as GeoTex®, or like material, to provide a sleeve that is puncture resistant and has a tear strength that

is sufficient to maintaining the forces exerted thereon when functioning as a water containment structure, and the sleeve is to receive at least one bladder that is preferably formed from a lightweight polyethylene material to have a capability to be filled with water to its capacity without rupturing. Which sleeve includes a filling tube of a length to rest on the bladder or bladders bottom, allowing the filling bladder or bladders contained within the sleeve with water, and which sleeve includes like notched sections in each end, and which end fingers are parallel and extend rearwardly from each notch such that the notch and finger form a U shape. The parallel fingers each receive a bladder end fitted therein to receive water, forming a water containment structure, and each sleeve finger end includes a vent port for venting air from the finger ends during bladder filling. In practice, the sleeve notched ends can each be fitted across opposite sides of a pair of wall ends or sides of a door opening, straddling that wall end or door way. Or which finger ends can be connected around a post. So arranged, the sleeve bladder or bladders, when filled with water, provide a water containing structure between the wall ends or across the doorway, or around a post, to prohibit waters from passing there across, and which sleeve ends of two sleeve can be connected end to end, as by laces, or the like, fitted through grommets formed at spaced intervals around the sleeve fingers edges and across the sleeve end notches, for joining end to end, forming a wall of connected sleeves forming a water containment structure.

[0013] The sleeve fingers top surface may be sloped relative to the finger bottom surface, from its junction with the end of the notch to the finger ends, to facilitate its fitting of the fingers along opposite sides of a doorway or wall sides, or the fingers may not be sloped within the scope of this disclosure. Each sleeve finger end configuration is blunt and includes an air vent formed therein, and the finger ends are essentially at right angles to the finger bottom surfaces, allowing the sleeve to be positioned together, end to end, at their notches for forming the continuous water containment structure, where the height of the joined sleeves, at their junction, will be essentially the same height as that of the filled sleeves. Additionally, the fingers ends can be joined around a pier or post and secured together, as by lacing, with the pier or post therebetween, providing an anchor for holding the sleeves in place.

[0014] In practice a strong flexible sleeve formed from GeoTex®, a material manufactured by Propex Operating Company, LLC, and bladder or bladders are formed from a lightweight polyethylene plastic, or the like, has been selected to provide a bladder that, when filled with water, is strong enough to resist punctures and the bladder ends, that fit into the sleeve finger ends, with each bladder or bladders preferably having a wall thickness of from (5) to (12) millimeters and is arranged for installation in the fabric sleeve of the invention prior to the bladder or bladders being filled with water. Though, it should be understood, the invention is not limited to any particular sleeve or bladder manufacture or thickness; can utilize sleeves and/or bladders of greater or lesser wall thickness; and the sleeve notch ends can be connected by lacing a lace cable through grommets formed in holes formed at spaced intervals along the junction of the sleeve top and bottom sections at the sleeve ends, or by other connection arrangement, for maintaining the sleeves fingers together, within the scope of this disclosure.

DESCRIPTION OF THE DRAWINGS

[0015] In the drawings which illustrate that which is presently regarded as the best mode for carrying out the invention:

[0016] FIG. 1 is a top plan view of a water containment structure of the invention that is shown as a sleeve with end center notches with like finger ends extending parallel to one another from the notch ends, forming like fingers that can be fitted across a wall or doorway, and showing the sleeve as containing a bladder consisting of a pair of closed tubes whose ends are fitted into the sleeve finger ends and showing, in broken lines each bladder tube, as including a fill tube that is of a length to rest on the bottom of a water filled bladder that extends out of the bladder tube top and sleeve and connects though a nozzle to a water source for filling, and which nozzle, when disconnected from the water source, can be used to pass water out from the bladder, filling and draining water therefrom, and shows air drains that extend out from the top of each bladder tube, and shows the sleeve fingers ends as each including an air vent;

[0017] FIG. 2 is an end view of the sleeve and with finger ends, less the wall or doorway, showing the sleeve as having a seam that extends around the sleeve mid-section, showing the seam formed from joined upper and lower sections, and showing the sleeve as containing bladder tubes that extend into the sleeve finger ends with each sleeve finger shown as including an air vent in the end thereof;

[0018] FIG. 3 is a side elevation view of the sleeve of FIG. 2, showing the slope of one of the sleeve parallel fingers as having an angle C slope, from the horizontal, with, it should be understood, the other sleeve fingers are identical thereto, and showing, in broken lines, the end of the sleeve notch;

[0019] FIG. 4 is an end perspective view of the sleeve showing the sleeve as formed from top and bottom sections of material that are secured together, as by lacing the sections together along their edges, showing the bladder tubes in broken lines, and, showing the bladder tubes in broken lines, as filled with water through the fill tubes, one in each bladder tube, with the fill ends thereof shown in solid lines as a nozzle that extends out from the sleeve, and showing bladders air drains adjacent to where the fill tube exits the sleeve, and showing, each of the sleeve fingers tubes ends as including an air vent, as are shown also in FIGS. 1, 2 and 3;

[0020] FIG. 4A is an enlarged end sectional perspective view taken from a notched end of the sleeve that shows aligned spaced eyelets as having metal rings fitted therein, forming grommets, that are arranged at spaced intervals along the edge of each sleeve fingers and notch, and shows a lace threaded through the spaced eyelets, for lacing the finger ends together, forming a water containing structure like that shown in FIGS. 6 and 8;

[0021] FIG. 5 is a view like that of FIG. 4 only showing the sleeve notches as positioned between vertical posts, and the bladder tubes, shown in broken lines, as having been filled with water, as illustrating by arrows A, and illustrating, with arrows B, the venting of air from the bladder tubes through air drains during filling of each of the pair of bladder tubes;

[0022] FIG. 6 shows sleeves like those of FIGS. 1 through 5, with the sleeves fingers shown as having blunt ends, and are connected, end to end at their notches, with the adjacent sleeve fingers along common edges, forming a continuous water containment structure;

[0023] FIG. 7 shows an end sectional view taken along the line 7-7 of FIG. 6 showing the water containment structure of FIG. 6 as holding back a weight of water on one side, and shows an adjacent section of the water containment structure of FIG. 6; and

[0024] FIG. 8 shows a damming structure like that of FIG. 7, except the water containment structure is shown formed into an arc.

DETAILED DESCRIPTION OF THE INVENTION

[0025] Temporary water structures that are erected at a location to be de-watered, to protect an area or structure from anticipated flooding, and are in common use. Such temporary water structures have included flexible sleeves containing a bladder or a pair of bladders, shown as tubes, for positioning at a site to be dammed, with the bladder tubes then filled with water to erect the water containment structure. Heretofore, however, such water containment structures have lacked versatility in that none have provided convenient arrangements for joining sleeves together in an end to end relationship. Further, earlier temporary water structures have needed to include at least an arrangement of two bladders in a single sleeve, and, have often required end anchors, for anchoring the water structure ends, to anchor the water structure to provide a dam that would resist side ways movement, or rolling, from water forces exerted onto one side of the sleeve, or have required that a pair of sleeves with tubes or bladders in each that have then been contained in an outer sleeve to resist rolling movement where lateral forces were exerted against the structure. Whereas, the invention provides a sleeve 11 with finger ends 12 extending from ends of a U shaped center notch 13, forming parallel fingers 12, and, as appropriate for its use the sleeve 11 fingers 12 can be sloped to fit and be conveniently maintained across a door way or wall end, and provides for joining the sleeve fingers 12 ends together around a post, or the like, for anchoring the sleeve 11 ends 12 thereto. Also, a plurality of sleeves 11 each having blunt ends, that are approximately the height of the sleeve body, and can be joined end to end by fitting sleeve fingers 12 together at the sleeve notch 13 to form a water containment structure 10 that will resist movement.

[0026] FIG. 1 shows a top plan view of the water containment structure 10 with sleeve 11 finger ends 12 of the invention. Shown therein, the water containment structure 10 includes the sleeve 11 having parallel fingers, 12 with a notch 13 there between, formed on opposite sleeve 11 ends. The sleeve 11 is shown as including a bladder, that is shown herein as a pair of individual tubes 14a and 14b, that are hereinafter referred to as bladder tubes 14a and 14b, with bladder tube ends 19a and 19b, that are preferably a pair of tubes that each have closed tube 19a and 19b ends. Which bladder tubes 14a and 14b extend the length of the sleeve, in parallel relationship, with their ends 19a and 19b fitted into, the finger ends 12 of sleeve 11. Each bladder tube 14a and 14b includes a fill tube 15a and 15b, that has a nozzle end 16a and 16b that extends out of the sleeve for filling the individual bladders with water and also provides for draining water from the bladder tubes 14a and 14b and bladder tube ends 19a and 19b, and each bladder tube 14a and 14b includes an air drain 17a and 17b that extends from the top of each bladder tube 14a and 14b, and is preferably adjacent to where the filling tube 15a and 15b and nozzle ends 16a

and 16b pass through the sleeve 11 and into the bladder tubes 14a and 14b, which air drain is preferably functions as a one-way valve, such as a flap valve, arranged to let air out of the bladder tubes 14a and 14b during filling and will close when the water level in the bladder tubes 14a and 14b reaches the air drain 17a and 17b.

[0027] Where the pair of bladder tubes 14a and 14b is shown herein as preferred, it should be understood that a single bladder, formed to fit within the sleeve 11 with ends therein fitted into the sleeve fingers 12, that includes a single fill tube 15a and 15b with nozzle end 16a and 16b and includes air drains 17a and 17b, could be used in the invention, within the scope of this disclosure. Additionally, air vents 18 are provided in the end of each sleeve finger 12 to facilitate venting air from the sleeve ahead of the bladder tubes 14a and 14b when the bladder tubes 14a and 14b are being filled with water through the fill tubes 15a and 15b. In practice, air vents 18 allow the bladder tubes 14a and 14b ends to fully fill the sleeve 11 and sleeve fingers 12 as the bladder tubes 14a and 14b are being filled with water.

[0028] FIG. 1 shows the water containment structure sleeve 11 fingers 12 fitted across an end of a structure 20, with the sleeve notch 13 in engagement with the structure end 20. This arrangement of the water containment structure 10 illustrates it's use to protect an area across the structure ends 20 that can be a door way, an area behind two walls, or the like. To facilitate fitting which sleeve 11 fingers 12 across a door way or between wall ends, as shown in FIGS. 2 and 3, the fingers 12 can be sloped at like slants from adjacent to or spaced a short distance towards the fingers 12 ends, from the sleeve notch 13, to each finger 12 end. Which slope is shown as angle C in FIG. 3, and, it should be understood, such slope can vary depending upon the use as the damming structure 10 is applied to. In practice, for fitting the sleeve 11 fingers 12 across a doorway or wall end, the slope is selected such that finger 12 fit conveniently around the doorway or wall end. In practice, the water containment structure 10 fingers 12 can be sloped at angle C that from essentially (0) zero to (90) degrees, within the scope of this disclosure. Such water containment structure 10 finger 12 slant facilitates the fitting of the fingers across the door way or wall end to the notch 13 such that the water containment structure 10 fingers 12 extend along the opposite sides of the doorway or wall ends 20, and to where the bladder 14a and 14b ends 19a and 19b will fit into the finger ends 12, with the air vents 18 in the water containment structure 10 finger ends providing for exhausting air from the space in-between which bladder 14a and 14b ends 19a and 19b outer surface and fingers ends 12.

[0029] Also shown in FIGS. 2 and 3, the sleeve 11 is preferably formed from a pair of like sections of sleeve material that, in practice, is preferably a strong, woven polypropylene geotextile type material that provides strength and is puncture resistance, and a GeoTex® flexible fabric material manufactured by Porpex Operating Company, LLC that is resistive to tearing even when it is pulled over rough terrain, has been used as the water containment structure 10. Though, it should be understood, other materials may be so utilized within the scope of this disclosure. In practice, the sections of material are formed as upper and lower sections that are laid out over one another and are secured together, along their common edges 11a, as shown in FIGS. 4 and 5, as by sewing, riveting, welding, or by other appropriate method, and spaced holes 25 are shown formed

at the common edges **11a** of the sleeve **12**, as shown also in FIG. **4A**. Which holes are preferably strengthened against tearing by fitted each with a metal ring, or the like, forming a grommet, and a rope, cable, or lace **25a**, for example, can be fitted through a first hole **25** and is laced through the adjacent aligned holes **25** for releasably joining the finger **12** ends together, as illustrated in FIGS. **6** and **8**, and as discussed below. The bladder tubes **14a** and **14b** with ends **19a** and **19b**, are preferably formed from of a lightweight polyethylene material, or like material, and are arranged in the sleeve **11** prior to closure of the sections of material forming the sleeve **11** having a common edge **11a**. In practice, a polyethylene material that has a thickness of from five (5) to twelve (12) millimeters has been used as the bladders **14a** and **14b** with ends **19a** and **19b**. Which bladders thickness is selected in consideration of the anticipated uses of the water containment structure **10**.

[0030] During the formation of the sleeve **11** of the water containment structure **10**, as shown in FIG. **4**, the bladder fill tubes **15a** and **15b** are preferably installed in the bladder tubes **14a** and **14b** and the fill tubes nozzle ends **16a** and **16b** are passed through the sleeve **11**, and the bladder air drains **17a** and **17b** are fitted into the bladder tubes **14a** and **14b** top surface, preferably adjacent to where the fill tubes nozzle ends **16a** and **16b** pass through the sleeve **11**, the completing the manufacture of the water containment structure **10**, that can be moved to a site and filled with water.

[0031] FIG. **4** shows spaced holes **25** that, preferably, have each been fitted with a reinforcing ring, forming a grommet, have been formed through the connected edges **11a** of the sleeve **11** top and bottom sections of material, and FIG. **5** shows the sleeve **11** ends **12** end edges **11a** as having been joined together, with a lace **25a** that is shown as having been laced through holes **25** on opposing sides of the ends **12** of the sleeve **11**, connecting the finger **12** ends of sleeves around a pole **30**. Which holes **25** and lace **25a**, are shown in FIGS. **6** and **8**, for connecting the fingers **12** water containment structure **10** sleeve **11** together in end to end relationship.

[0032] Shown in FIG. **5**, opposite finger ends **12** of the sleeve **11** are positioned around poles **30**, and the bladders **14a** and **14b** are shown as having been filled with water to there ends **19a** and **19b**, form an erected water containment structure **10** that is supported between which poles **30**. To further anchor the water containment structure of FIG. **5**. As shown, the ends of fingers **12** of each sleeve **11** end can be wrapped around each pole **30** such that and the sleeve **11** ends **13** forward edges **11a** come together such that the spaced holes **25** align and can receive the lace **25a** laced through the spaced holes **25**, locking the sleeve ends together,

[0033] FIG. **6** shows a linking, end to end, of a plurality of sleeves **11** to form a water containment structure **10** that extends across an area to be dammed, as for de-watering, or the like. Which arrangement of sleeves **11** involves fitting a sleeve **11** finger end **12** of a first sleeve into a notch **13** of a next or second sleeve **11** finger end such that the fingers **12** of the first and second sleeves **11**, and continuing sleeve ends attachment to form the water containment structure, as shown in FIG. **6**. For connecting the sleeve **11** ends **12** together, the ends are fitted side by side and their edges **11a** are over lapped so as to align the individual spaced holes **25**, as illustrated in FIGS. **4A** and **5**, of the first sleeve and second sleeves to receive a lace **25a** that is laced through

each pair of aligned holes **25**, across and along abutting first and second sleeve finger ends, along the second finger notch and along the abutting first and second sleeve finger ends. Which lace ends are secured, as by knotting the ends thereof, to prohibit back passage through the holes **25**, securing the coupling of the first and second sleeves **11** ends together. Which connections of sleeves **11** together are continued to form a desire length of water containment structure. Followed by filling the individual bladder tubes **14a** and **14b** with water that is passed through fill tubes **15a** and **15b** and nozzles **16a** and **16b**, forming water containment structure **10**, as shown in the sectional view of FIG. **7**. Which sectional view of FIG. **7** shows a cross sectional view of a first sleeve **11** with a pair of bladder tubes **14a** and **14b** therein, and shows the outer surface of an adjacent sleeve **11** that curves away from the first as having also been filled with water, forming the water containment structure **10** that, as shown, is holding back a level of water **30**, which sleeves **11** and fingers **12** of the first and second water containment structure, it should be understood, have a same height to provide, when joined end to end, a constant height of water containment structure **10**.

[0034] FIG. **8** also shows a water containment structure **10** formed from joined first and second sleeves **11** fitted together, end to end, like the water containment structure **10** of FIG. **6**, showing the first and second sleeve finger ends **12** and notches **13** as connected together, only, showing the water containment structure of FIG. **8** arranged in an arc and maintained between wall ends **20**, like the single sleeve **11** arrangement, shown in FIG. **1**. Which water containment structure **10** arrangements of FIGS. **1**, **6** and **8**, illustrate the variety of applications the water containment structures **10**, that each include the sleeve **11** with fingers **12** and notch **13** ends, can be used for to form a long water containment structure maintained between anchored ends. In forming which water containment structures **10** shown in FIGS. **6** and **8**, the slope of the fingers **12** top surface is from approximately the notch **13** to the finger **12** end of each finger, and is such that, when the fingers are positioned side by side, will provide a water containment structure whose profile is essentially uniform along its length, as shown in FIGS. **6** and **8**.

[0035] While not shown, it should be understood that the sections of material forming sleeve **11** could be secured together along their junctions as with a zipper, or like closure, to allow access to the bladder tubes **14a** and **14a**, and that, within the scope of this disclosure, and that a single bladder or closed tube can be formed to have ends arranged to fit into the sleeve fingers **12**, extending between the opposite sleeve fingers ends.

[0036] The water containment structures **10**, as illustrated in FIGS. **1** and **5** through **8**, represent structures that will, when erected, hold back a body of, or flow of, water. In holding back such body of water, as when the wind passes over such body of water, wave actions may be created that tend to move former water containment structures. Where earlier temporary water containment structures have met this problem by containing two or three water filled vessels within an outer sleeve to discourage a wave action from causing rolling of the water containment structure, and other arrangement have utilized anchors, or the like. Additional to the connection of the the sleeve finger ends across or around a fixed structure, as illustrated in FIGS. **1** and **5**, the connected sleeve ends themselves, as shown in FIG. **6**,

provides, as shown in FIGS. 6 and 8, sleeve fingers 12 that extend away from the faces of the water containment structure that function outriggers, that block rolling of the water containment structure 10 do to wind action, thereby discouraging the water containment structure 10 from moving or rolling even when the water containment structure 10 holds back a level of water that is being subjected to wind forces.

[0037] The invention is a use of a sleeve or sleeves formed of a strong, puncture resistive and durable material such as GeoTex® manufactures by Propex Operating Company, LLC, has been used in practice, through, it should be understood another like material could be so used within the scope of this disclosure. The sleeve or sleeves are to receive a bladder or a pair of bladder tubes whose ends have been closed to be filled with water that are preferably formed from a material, such as a flexible polyethylene plastic, that is strong enough to resist punctures and has a range of wall thicknesses of five (5) to twelve (12) millimeters, through, it should be understood bladders or tubes having greater or less thickness could be used within the scope of this invention depending upon the sleeve size, and it should, therefore, be understood, the invention is not limited to any particular sleeve material or bladder or bladder tube material or to a particular wall thickness of bladder or tube forming material and that other appropriate sleeve materials bladder or bladder tubes can be used within the scope of this disclosure.

[0038] Although preferred embodiments of the invention have been shown and described herein, it should be understood that the present disclosure is made by way of example only and that variations are possible, within the scope of this disclosure, without departing from the subject matter coming within the scope of the following claims and reasonable equivalency thereof, which claims I regard as my invention.

I claim:

1. A water containment structure comprising, a sleeve that is formed from a lightweight puncture resistant flexible material that is closed at opposite ends, and each said sleeve opposite ends include a U-shaped notch between a pair of fingers that extend outwardly from opposite sides of each said U-shaped notch that are parallel to one another, and each of said fingers has a closed at end; a flexible bladder that is that is strong enough to resist punctures and is formed to fit within said sleeve and said sleeve fingers; a fill tube with nozzle end fitted through said sleeve and sealed through said flexible bladder to pass water into and drain water out from said flexible bladder; bladder air drains arranged through a top surface of said flexible bladder that are to vent air out from beneath said top surface of said flexible bladder during filling with water, and to close when a level of water in said flexible bladder reaches said bladder air drain, and said like sleeve fingers each have air vents fitted through said fingers ends for venting air during filling of said flexible bladder with water; and lace means for joining a plurality of said sleeves together in end to end relationship, connecting said first and second flexible sleeves ends fingers and notches of said first and second flexible sleeves together, forming a continuous water containment structure, which lace means consists of a flexible lace that is threaded through aligned holes formed through aligned edges of said sleeves fingers and notches and provides for connecting the ends of said flexible lace together.

2. The water containment structure as recited in claim 1, wherein the flexible bladder consists of first and second

flexible bladder tubes that are arranged alongside one another within the flexible sleeve and are formed to be filled with water, where each of said first and second flexible bladder tubes extend from an outer end of one flexible sleeve finger to an end of an opposite flexible sleeve outer end.

3. The water containment structure as recited in claim 2, wherein the sleeve ends each include a pair of fingers that are separated by a notch, and each said finger is sloped from the horizontal adjacent to its junction with the flexible sleeve notch end to the outer end of said flexible sleeve finger end at an angle that is from horizontal to vertical.

4. The water containment structure as recited in claim 1, wherein the flexible sleeve is formed from flat upper and lower sections of the lightweight puncture resistant flexible material that are secured together along their edges.

5. The water containment structure as recited in claim 1, wherein the flexible bladder is formed from a flexible polyethylene plastic, to be strong enough to resist punctures and has a range of wall thicknesses of from five (5) to twelve (12) millimeters.

6. The water containment structure as recited in claim 2, wherein, the flexible bladder air drains are mounted through the top surface of each of the first and second flexible bladder tube that are positioned in side by side relationship in the flexible sleeve and are each arranged to close when contacted by a level of water, and the air vents that are fitted into each said sleeve finger end are arranged to vent air from between each said first and second flexible bladder end and said sleeve finger end during water filling of said first and second flexible bladders.

7. A water containment structure comprising, a plurality of water containment structures that each include first and second flexible sleeves that are each formed from a lightweight, puncture resistant flexible material and each said first and second flexible sleeve is closed at opposite ends, and each said first and second flexible sleeves opposite ends include a notch with like sleeve fingers formed between ends of said U-shaped notch that extend at right angles outwardly from ends of said U-shaped notches and said sleeve fingers are in parallel relationship to one another, and each said sleeve finger is closed at an outer end thereof; a flexible bladder consisting of a pair of bladder tubes that are formed to fit within and fill each said first and second flexible sleeves, filling each said first and second flexible sleeves to said sleeve finger ends; a fill tube with nozzle end for filling and draining water into and from each of said pair of flexible bladder tubes and each said fill tube fitted through a top surface of each said bladder tube and through a top surface of each of said pair of first and second flexible sleeves and which said fill tube also provide for venting air from within each said first and second flexible bladders during their filling with water and the ends of each said first and second flexible sleeves fingers ends includes an air vent; and means for releasably connecting the first and second flexible sleeves fingers and notches of said first and second flexible sleeves together, in end to end relationship, forming a continuous water containment structure consisting of a flexible lace means that is threaded through aligned holes formed through aligned edges of said first and second flexible sleeves fingers and notches, and ends of said flexible lace means are formed for connection together.

8. The water structure as recited in claim 7, wherein the first and second flexible sleeve ends fingers and notches each include holes formed; at equal spaced intervals through

inner and outer edges of said first and second flexible sleeves fingers ends and notches, and said holes are to align to receive a lace means, laced through said holes, and ends of said lace include capped ends to facilitate their passage through said aligned holes and are connected together as by forming a bow therein or by knotting them together so as to prohibit said lace means from being drawn out from said aligned holes.

9. The water structure as recited in claim 8, further including fitting each of the holes with a metallic eyelet forming grommets.

10. The water containing damming structure as recited in claim 7, wherein the flexible are each formed from upper and lower sections of a light weight puncture resistant flexible material that are secured together along edges of said upper and lower sections.

* * * * *